



Visualisation; Diagnostics

Easy to Configure

Programming IEC 61131-3

Rapid Installation

PSEN sc L 3/5 series

PILZ
THE SPIRIT OF SAFETY

► PSEN sensor technology

This document is the original document.

All rights to this documentation are reserved by Pilz GmbH & Co. KG. Copies may be made for the user's internal purposes. Suggestions and comments for improving this documentation will be gratefully received.

Source code from third-party manufacturers or open source software has been used for some components. The relevant licence information is available on the Internet on the Pilz homepage.

Pilz®, PIT®, PMI®, PNOZ®, Primo®, PSEN®, PSS®, PVIS®, SafetyBUS p®, SafetyEYE®, SafetyNET p®, the spirit of safety® are registered and protected trademarks of Pilz GmbH & Co. KG in some countries.



SD means Secure Digital

1	Introduction	6
1.1	Validity of documentation	6
1.2	Using the documentation	6
1.3	Definition of symbols	6
2	Overview	8
2.1	Device features	8
2.2	Unit view	9
3	Safety	11
3.1	Intended use	11
3.2	Safety regulations	12
3.2.1	Safety assessment	12
3.2.2	Use of qualified personnel	12
3.2.3	Warranty and liability	12
3.2.4	Disposal	12
3.3	For your safety	13
4	Function description	14
4.1	Basic function of the safety laser scanner	14
4.2	Use of zone sets and monitoring cases	15
4.3	Automatic and monitored start/restart	15
4.4	Manual restart	16
4.5	OSSD	16
4.6	Reset	17
4.7	EDM	17
4.8	Wave	18
4.9	Muting	18
4.10	Override	20
4.11	Stationary hazardous area	21
4.12	Multiple evaluation	21
4.13	Monitoring of reference outlines	22
4.14	Restore configuration	22
4.15	Examples of application	23
4.15.1	Horizontal application	23
4.15.2	Vertical application	24
4.15.3	Mobile application	25
5	Project configuration	26
5.1	Maintaining the safety distance	26
5.1.1	General	26
5.1.2	Horizontal application with stationary danger zone	27
5.1.3	Horizontal application with automated guided vehicle systems	29
5.1.4	Vertical application	31
5.2	Calculation of the overall response time	32
5.3	Reference outline monitoring	32
5.4	Area with limited detection capability	32
5.5	Installation of several adjacent safety laser scanners	33

5.6	Ambient conditions	34
5.7	Distance to intense light sources and to reflective surfaces	34
5.8	Distance from walls	38
5.9	Planning of safety and warning zones and zone sets	38
5.10	Switchover time with zone selection	38
5.11	Determining the moment of switchover	38
5.12	Dust filtration	39
5.13	Muting	40
5.13.1	General	40
5.13.2	Muting in one direction	41
5.13.3	Muting in two directions	42
5.13.4	Dynamic muting	43
5.14	Override	43
6	Wiring	45
6.1	General guidelines	45
6.2	Connector pin assignment	45
6.2.1	Configurable inputs	47
6.2.2	Configurable inputs/outputs	48
6.3	Wiring of the configurations	48
6.4	Connect supply voltage and safety controller	48
6.5	Connection to PSEnscan Configurator	50
6.6	Connections for muting sensors	52
7	Installation and alignment	53
7.1	Installation options	53
7.2	Installation without PSEN sc bracket H	53
7.3	Installation of the protective bracket PSEN sc bracket H at the safety laser scanner	54
7.4	Installation with setting of angle of inclination/roll angle - bracket PSEN sc bracket PR	55
7.5	Installation with angle of inclination setting - holder PSEN sc bracket P	57
7.6	Set the angle of inclination of the safety laser scanner	58
7.7	Set the side inclination of the safety laser scanner	58
7.8	Measures to safeguard unsecured areas	59
8	PSEnscan Configurator	61
8.1	Basics	61
8.2	Installation	61
8.2.1	System requirements	61
8.2.2	Install PSEnscan Configurator	61
8.2.3	Ethernet Connections	62
8.2.3.1	Factory default settings for the IP addresses	62
8.2.3.2	Create firewall rule	62
8.2.3.3	Connect automatically	62
8.3	Download configuration to device	63
8.4	Create backup copy of a configuration	64
9	First commissioning	65
9.1	Requirements for commissioning	65

9.2	System connection	65
9.3	Configuration of zones	66
9.3.1	Example for an 8-pin connection	66
9.3.2	Example for an 12-pin connection	68
9.4	Testing	71
10	Operation	73
10.1	Display during normal operation	73
10.2	Display of the monitoring status	74
10.3	Diagnostic information	75
10.3.1	Error	75
10.3.2	Warnings	77
10.3.3	Information	78
10.4	Text messages in the display	78
10.5	Restore configuration	80
10.6	Reset	81
11	Safety checks, maintenance and repair	82
11.1	Cleaning	82
11.2	Checks	83
11.2.1	Regular check	83
11.2.2	Check after plant/machine modification	83
11.3	Maintenance	83
12	Dimensions	84
13	Technical details order no. 6D000012-6D000013	86
14	Safety characteristic data	89
15	Network data	90
16	Order reference	91
16.1	System	91
16.2	Accessories	91
17	Appendix	93
17.1	Check list	93
18	Identification	96
19	EC declaration of conformity	97

1 Introduction

1.1 Validity of documentation

This documentation is valid for the product PSEN sc L 3/5 series from Version 1.0.

This operating manual explains the function and operation, describes the installation and provides guidelines on how to connect the product.

1.2 Using the documentation

This document is intended for instruction. Only install and commission the product if you have read and understood this document. The document should be retained for future reference.

1.3 Definition of symbols

Information that is particularly important is identified as follows:



DANGER!

This warning must be heeded! It warns of a hazardous situation that poses an immediate threat of serious injury and death and indicates preventive measures that can be taken.



WARNING!

This warning must be heeded! It warns of a hazardous situation that could lead to serious injury and death and indicates preventive measures that can be taken.



CAUTION!

This refers to a hazard that can lead to a less serious or minor injury plus material damage, and also provides information on preventive measures that can be taken.



NOTICE

This describes a situation in which the product or devices could be damaged and also provides information on preventive measures that can be taken. It also highlights areas within the text that are of particular importance.



INFORMATION

This gives advice on applications and provides information on special features.

2 Overview

2.1 Device features



The safety laser scanners of the PSEN sc L 3/5 series are electrosensitive protective equipment (ESPE type: 3) in accordance with EN 61496-3 for workspaces in which machines, robots, and automated systems could endanger the physical integrity of operators.

- ▶ Detection capability: 40 mm, 70 mm
- ▶ 2 protective zones independent of each other (one OSSD pair per protective zone)
- ▶ LED display and display for status information
- ▶ Scan angle: 275°
- ▶ Infrared laser beams build up a 2-dimensional protected area
- ▶ Separation of the protected area in a safety zone and a warning zone
- ▶ Number of **zone sets**  14] that can be switched
 - PSEN sc L with 8-pin connection = 3
 - PSEN sc L with 12-pin connection = 10
- ▶ Enhanced availability by configurable multiple evaluation
- ▶ The safety laser scanner can be installed and operated overhead.
- ▶ Muting
 - Muting in one direction
 - Muting in two directions
 - Dynamic muting

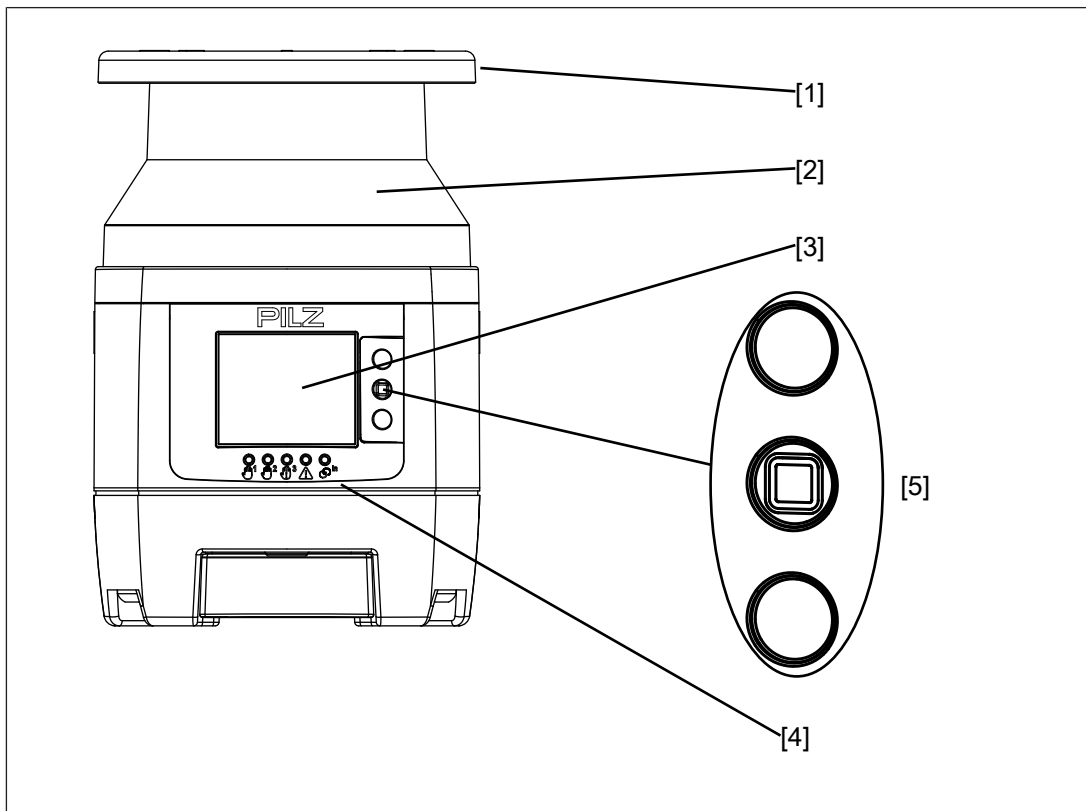
2.2 Unit view



Legend

- [1] Metal cover upper side
- [2] Front panel (exit laser beams)
- [3] Display for device messages
- [4] LEDs as status indicator
- [5] Buttons for scrolling in the display or to confirm the message in the display
-  Scroll up
-  Confirm message in the display
-  Scroll down

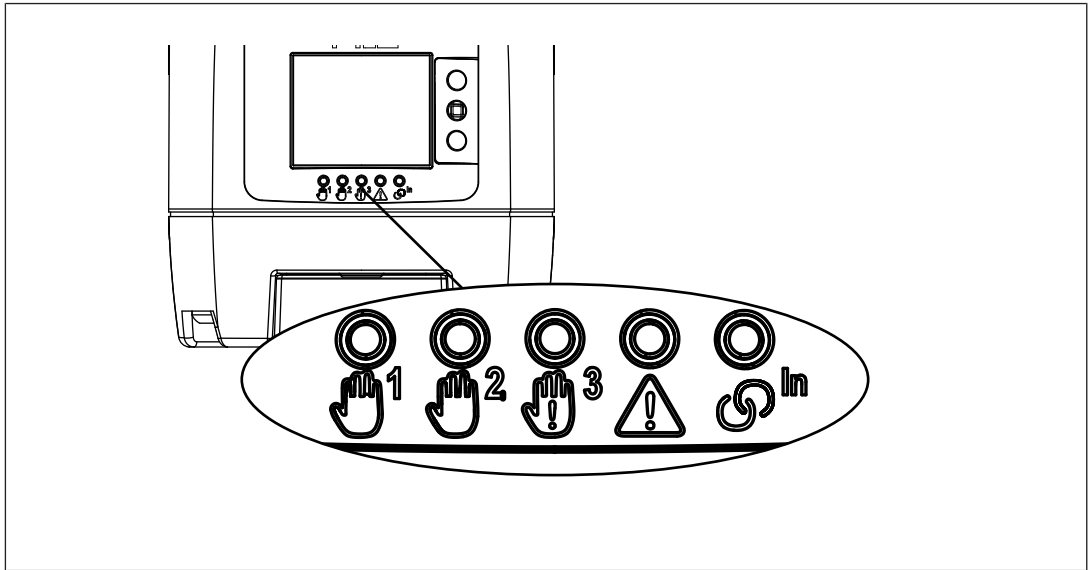

Legend

- 

 Status of the OSSD 1/2 Lights up green: No object detected in safety zone
 Lights up red: Object detected in safety zone

- 

 Not used

- 

 Status of the warning zone 2 off: No object detected in warning zone 2
 Lights up yellow: Object detected in warning zone 2



- 

 Status of the warning zone 1 off: No object detected in warning zone 1
 Lights up yellow: Object detected in warning zone 1

- 

 Locking Lights up yellow and

 lights up red:

 - No object detected in safety zone, PSEN sc L 3/5 series waits for manual restart
 - off and  lights up green: No object detected in safety zone, PSEN sc L 3/5 series is ready for operation
 - off and  lights up red: Object detected in safety zone, PSEN sc L 3/5 series in OFF state

3 Safety

3.1 Intended use

The safety laser scanners of the PSEN sc L 3/5 series are electrosensitive protective equipment of ESPE type 3. They are used to protect personnel and systems. The safety laser scanners are designed to

- ▶ secure danger zones within buildings,
- ▶ secure danger zones of vehicles and
- ▶ protect the access within buildings.

The safety laser scanner may only be used for personal protection on machinery if

- ▶ the hazardous state can be removed by the safety laser scanner and
- ▶ the starting of the machine is controlled by the safety laser scanner and
- ▶ the safety assessment prescribes no better detection capability than 40 mm, 70 mm.

The safety level PL d (Cat. 3)/SIL CL 2 is only achieved if

- ▶ The safety outputs must be processed safety-related in 2-channel mode.

The restart of the machine or vehicle can be performed using a manual or an automatic restart.

- ▶ It must not be possible to operate the pushbutton for manual restart from inside the danger zone. The pushbutton must be located at a position from which there is a full, unobstructed view of the danger zone.

Prevent circumvention of the safety zone. This means that other electrosensitive protective equipment and protective measures may be required in addition to the safety laser scanner. These should be determined via a safety assessment based on the specific application range and specific local conditions (e.g. official specifications).

Refer to IEC/TS 62046 to determine other necessary safeguards for securing the danger zone.

Their application must fulfil the site's relevant national regulations (e. g. EN 60204-1, NFPA 79:17-7).

The following is deemed improper use in particular

- ▶ Any component, technical or electrical modification to the product,
- ▶ Use of the product outside the areas described in this manual,
- ▶ Use of the product outside the technical details (see [Technical details](#)  86]).



NOTICE

EMC-compliant electrical installation

The product is designed for use in an industrial environment. The product may cause interference if installed in other environments. If installed in other environments, measures should be taken to comply with the applicable standards and directives for the respective installation site with regard to interference.

Foreseeable misuse

- ▶ The safety laser scanner may **not** be accessed and may **not** be used as a step.
- ▶ The PSEN sc bracket H mounted on the safety laser scanner may **not** be accessed and **not** be used as a step
- ▶ The safety laser scanner may **not** be used at an ambient temperature below 0°.
- ▶ The safety laser scanner may **not** be built into an additional housing.

3.2 Safety regulations

3.2.1 Safety assessment

Before using a device it is necessary to perform a safety assessment in accordance with the Machinery Directive.

Functional safety is guaranteed for the product as a single component. However, this does not guarantee the functional safety of the overall plant/machine. In order to achieve the required safety level for the overall plant/machine, define the safety requirements for the plant/machine and then define how these must be implemented from a technical and organisational standpoint.

3.2.2 Use of qualified personnel

The products may only be assembled, installed, programmed, commissioned, operated, maintained and decommissioned by competent persons.

A competent person is a qualified and knowledgeable person who, because of their training, experience and current professional activity, has the specialist knowledge required. To be able to inspect, assess and operate devices, systems and machines, the person has to be informed of the state of the art and the applicable national, European and international laws, directives and standards.

It is the company's responsibility only to employ personnel who

- ▶ Are familiar with the basic regulations concerning health and safety / accident prevention,
- ▶ Have read and understood the information provided in the section entitled Safety
- ▶ Have a good knowledge of the generic and specialist standards applicable to the specific application.

3.2.3 Warranty and liability

All claims to warranty and liability will be rendered invalid if

- ▶ The product was used contrary to the purpose for which it is intended,
- ▶ Damage can be attributed to not having followed the guidelines in the manual,
- ▶ Operating personnel are not suitably qualified,
- ▶ Any type of modification has been made (e.g. exchanging components on the PCB boards, soldering work etc.).

3.2.4 Disposal

- ▶ In safety-related applications, please comply with the mission time T_M in the safety-related characteristic data.

- ▶ When decommissioning, please comply with local regulations regarding the disposal of electronic devices (e.g. Electrical and Electronic Equipment Act).

3.3 For your safety

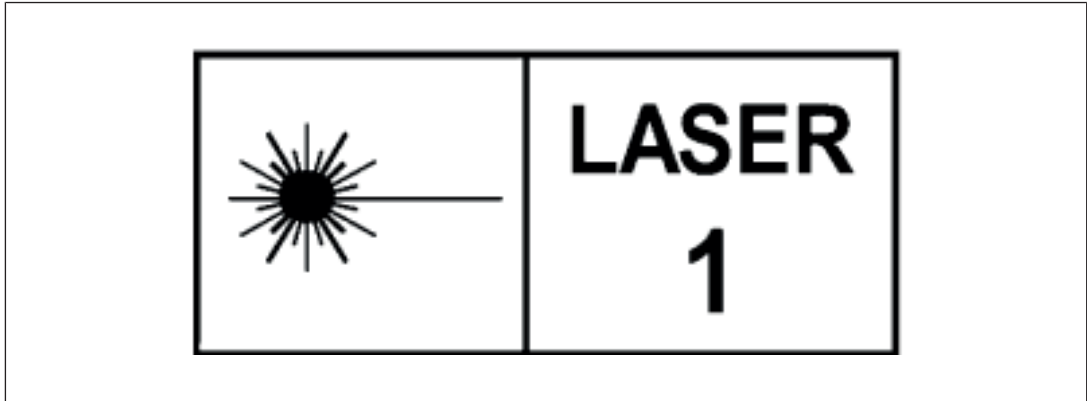

INFORMATION

Laser radiation of the safety laser scanner

The safety laser scanner of the PSEN sc L 3/5 series corresponds to the laser class 1 in accordance with EN 60825-1. Additional measures to shield the laser beams are not required (eye-safe).

4 Function description

4.1 Basic function of the safety laser scanner

The safety laser scanner monitors an area that is covered by the light beam emitted by the safety laser scanner.

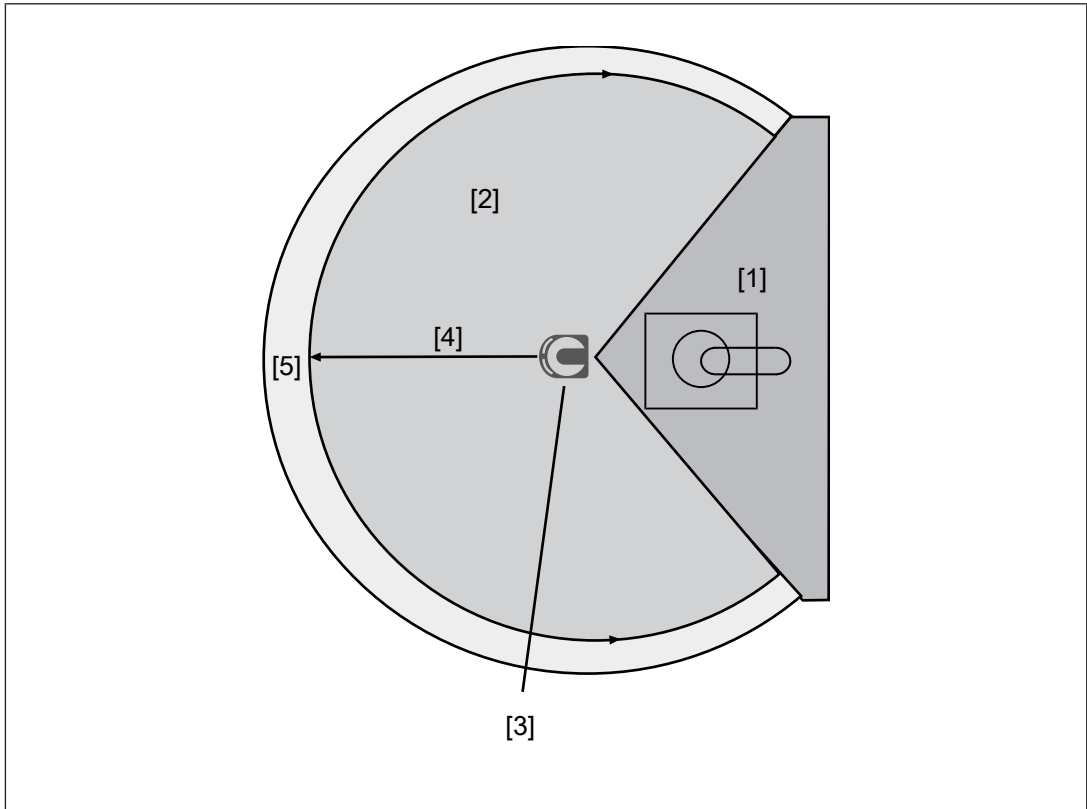

Fig.: Operating principle safety laser scanner

Legend

- [1] Danger zone
- [2] Area covered by the laser beam
- [3] Safety laser scanner
- [4] Safety zone
- [5] Warning zone

The area can be divided into a safety zone and a warning zone.

If an object or a person enters the warning zone, corresponding actions can be triggered (e.g. switch on indicator light unit).

If an object or a person violates the safety zone, the OSSDs switch to an OFF state.

4.2 Use of zone sets and monitoring cases

A safety zone and one or two warning zone(s) constitute a zone set.

A monitoring case is a defined signal at the control inputs for the current machine state. For **one** specific machine state, **one** specific monitoring case can be assigned.

The safety laser scanner uses the defined signal at the control inputs to activate the zone set, which is assigned to this monitoring case and therefore to a specific machine state.

When a machine has e.g. different operating statuses, a safety laser scanner can be used to monitor several operating statuses.

When using two zone sets, the monitoring of zone set 1 can be switched to the monitoring of zone set 2. The switching is controlled by the configurable inputs.

The standard behaviour when switching the monitoring cases does not plan an overlap of the zone sets.

- ▶ Max. number of zone sets
 - PSEN sc L with use of 8-pin connection: 3
 - PSEN sc L with use of 12-pin connection: 10
- ▶ Max. number of inputs for switching zone sets
 - PSEN sc L with use of 8-pin connection: 3
 - PSEN sc L with use of 12-pin connection: 5

4.3 Automatic and monitored start/restart

Automatic start/restart

After switching on the safety laser scanner or re-release of the safety zone, the safety laser scanner automatically starts, and the OSSDs switch to the ON state under these conditions:

- ▶ Both OSSDs are wired correctly **and**
- ▶ No fault has occurred **and**
- ▶ the safety zone is free.

If the safety zone is violated, the OSSDs switch to the OFF state.

Monitored manual start/restart

The OSSDs switch to the ON state during operation under the following conditions:

- ▶ Both OSSDs are wired correctly **and**
- ▶ No fault has occurred **and**
- ▶ The safety zone is free **and**
- ▶ at least 80 ms have elapsed since switching to the OFF state **and**
- ▶ The start button has been operated and then released again for a min. 0.5 s and a max. 5 s. The start occurs with a falling edge.

4.4 Manual restart

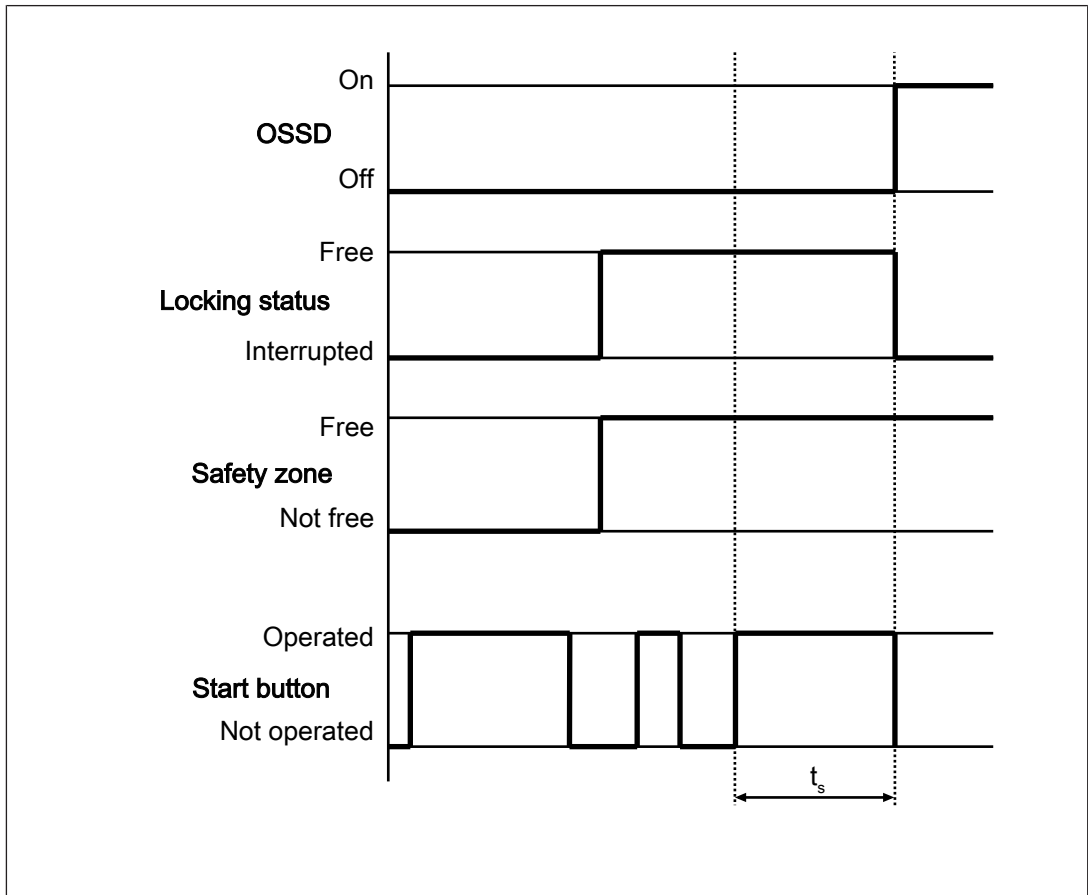

Fig.: Timing diagram for manual restart

Legend

t_s Operate the start button for 0.5 s to 5 s to trigger a manual restart

4.5 OSSD

The switched on OSSDs are permanently checked by monitored test pulses. In the case of detected errors at the OSSDs, the safety laser scanner switches to the error status.

4.6 Reset

The Reset function can be used to set the safety laser scanner back to normal operation, when the safety laser scanner has changed to an error state because of a non-critical error.

The reset pushbutton has to be connected to the reset input.

To trigger a reset, the reset pushbutton has to be pressed for at least 500 ms.

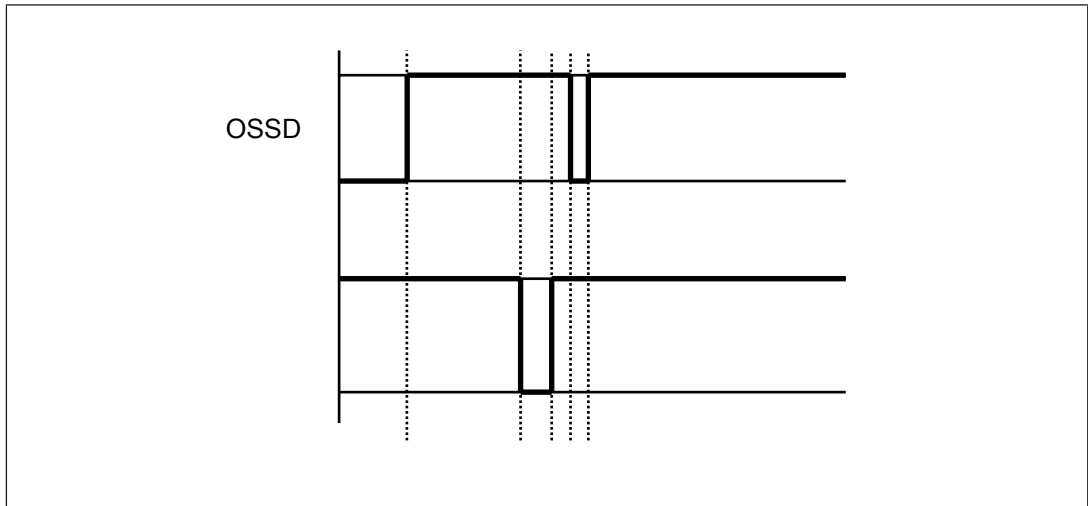

Fig.: Timing diagram reset

4.7 EDM

Contactors outside the safety laser scanner can be monitored (External Device Monitoring = EDM, also known as feedback loop monitoring).

EDM only needs to be activated if the contactors are controlled directly.

A test is performed to see that the N/C contacts switch if the state of the OSSDs changes and so is used to monitor and detect malfunctions on the contactors. If a malfunction is detected, the safety laser scanner switches to a safe condition and stops the connected machine. This check is carried out each time the OSSDs are triggered and before restarting.

The EDM function is available:

- ▶ Only when using the 12-pin connection
- ▶ Only for the OSSD pairs 1 and 2.

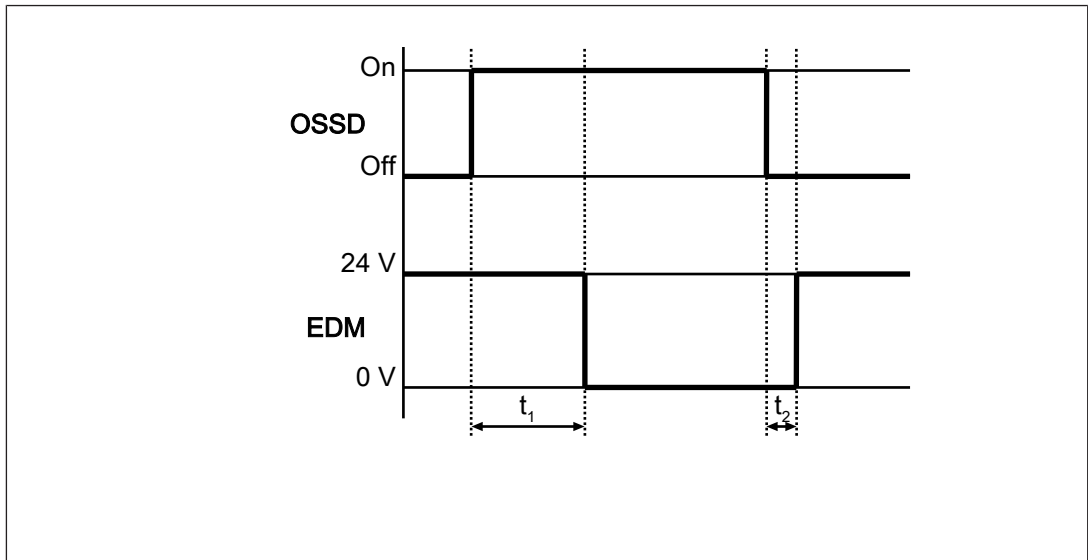

Fig.: Timing diagram for EDM

Legend

- t_1 After the OSSD outputs are switched on, the EDM circuit must open within 350 ms
- t_2 After the OSSD outputs are switched off, the EDM circuit must close within 100 ms

Use control elements whose dynamics match the times stated at t_1 and t_2 .

The function is activated or deactivated with the [Wiring](#)  45].

4.8 Wave

With the wave function, a safety laser scanner that is to be configured in a network can be identified more easily from its position.

When starting the automatic search for a safety laser scanner in a network the wave button can be selected.



The device found registers with the flashing message  in the display.

4.9 Muting

The muting function can be used to suspend the safety laser scanner during operation, subject to special operating conditions.

► Example of a special operating condition:

Material is transported into the protective zone on a conveyor and the safety laser scanner is overridden for the time it takes the material to pass through.

Muting proves to be particularly suitable when, under certain operating conditions, an object is permitted to pass through the danger zone but a person is not.

Identification of the conveyed material (pallets, vehicles...) must be guaranteed with all

- ▶ Material dimensions and
- ▶ Conveyor speeds

that are intended to arise during operation.

The muting sensors are connected to muting inputs 1 and 2. The muting sensors must be positioned and installed at a right angle to the safety laser scanner (see [Installation and wiring](#) [ 53]).

- ▶ When the muting state of the safety laser scanner is detected, the safety laser scanner triggers the configured actions for the muting state (e.g. switch on warning lamp or warning sound).
- ▶ Muting can be used in various versions.

- L muting: Transport of material in one direction
- T muting: Transport of material in two directions
- Dynamic muting: Available for L muting and T muting

In addition to the conditions for L muting and T muting, activation and deactivation of the muting state can be controlled by the connected safety controller.

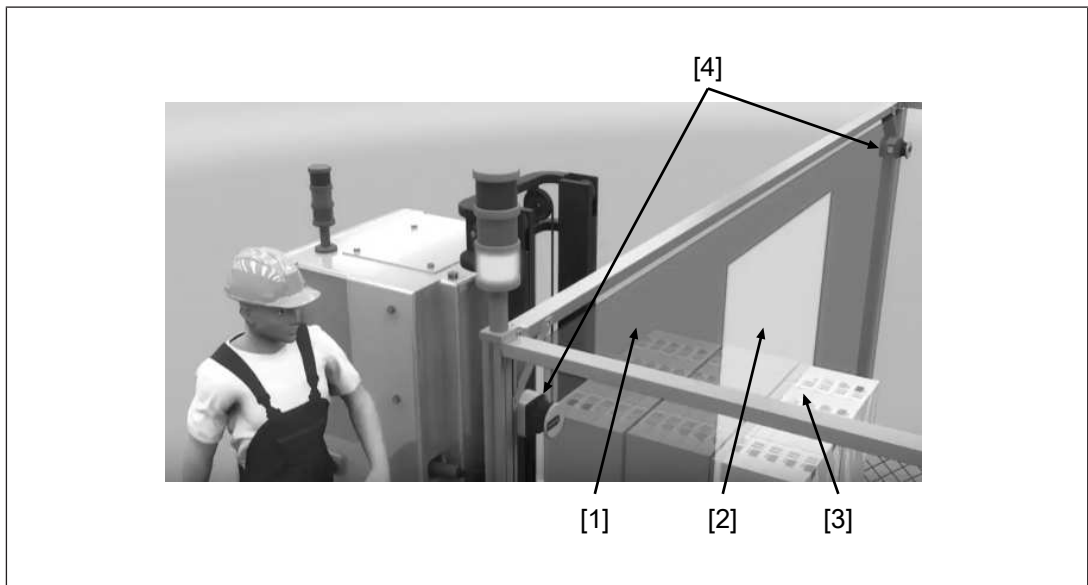

Legend

- [1] Protective zone
- [2] Muting zone
- [3] Transported material
- [4] Safety laser scanner



CAUTION!

Risk of injury due to loss of the safety function

In muting status, the OSSDs continue to be in ON state. The connected machine remains in operation and represents a potential hazard.

- Prevent access to the danger zone during muting.

- ▶ The muting state is shown by the muting lamp and in the display of PSEN sc L 3/5 series. The muting lamp must be connected to the PSEN sc L 3/5 series and positioned so that the muting lamp is clearly visible from the whole danger zone.



- ▶ Use a muting lamp with an LED lamp and a max. current consumption of 250 mA.
- ▶ If the muting lamp is defective, the muting function cannot be activated. Any attempt to activate the function will immediately trigger the PSEN sc L 3/5 series and instantly switch off the OSSDs; the muting lamp fault indicator will also light.

4.10 Override

With the override function, a machine can be restarted even though the safety zone is violated by material.

The aim is to clear the danger zone of any material that may have accumulated due to a fault in the operating cycle.

If there is a pallet in the safety zone, for example, and the conveyor can no longer be switched on because the safety laser scanner is keeping the OSSDs switched off (because the safety zone is not free), the accumulated material cannot be transported away from the zone.

Activating the override function allows intervention and enables the conveyor to be restarted.

The safety laser scanner has two connections for override, which are connected via N/O contacts at 24 VDC (Override 1) and 0 VDC (Override 2). Both contacts are closed if the override function is activated.

Automatic ending of override function

The override function is ended automatically when one of the following conditions is met:

- ▶ Muting timeout has elapsed
- ▶ The conditions necessary for activation are no longer present.
- ▶ Max. duration of override function has elapsed: After 120 s, the safety laser scanner switches back to its normal operating status.
- ▶ No muting sensor is active
- ▶ Safety zone is not violated

4.11 Stationary hazardous area

Using the safety laser scanner, you can monitor a stationary danger zone, e.g. the environment of a machine that is installed in a fixed position.

The monitored area can be divided into subsections, for which monitoring can be activated and deactivated each.

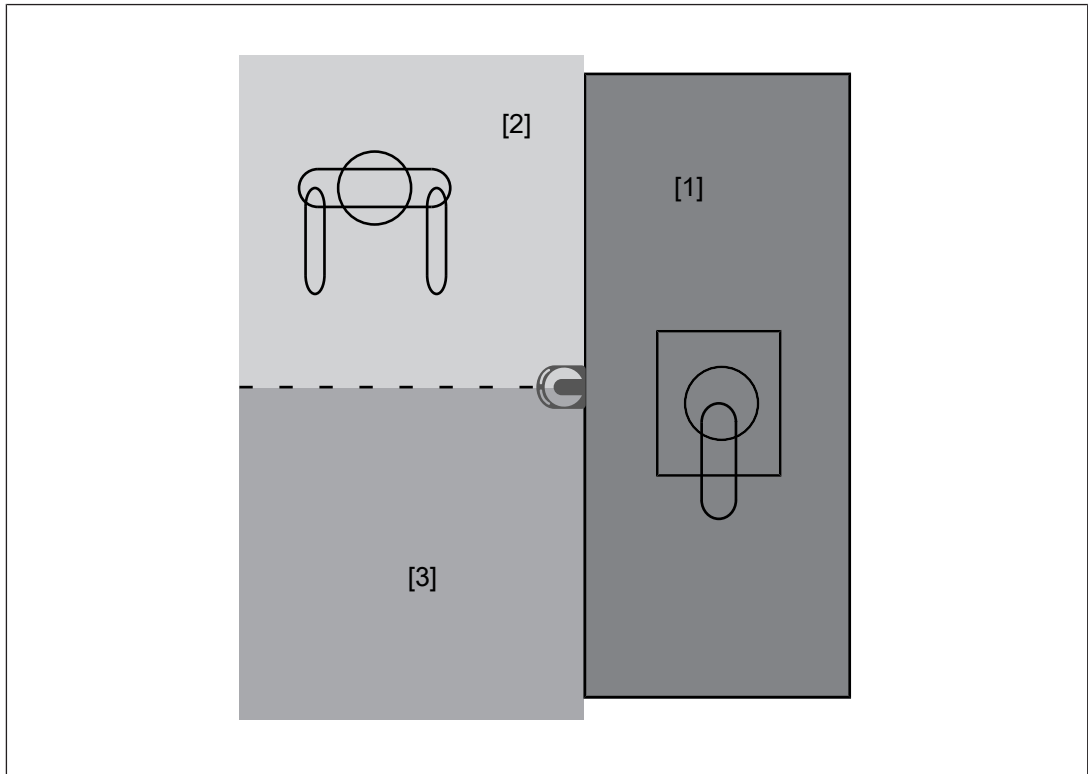

Legend

- [1] Danger zone
- [2] Configured zone 1, monitoring not activated
- [3] Configured zone 2, monitoring not activated

4.12 Multiple evaluation

When multiple evaluation is active, an object has to be scanned several times consecutively before the safety laser scanner switches the OSSDs to the OFF state. This reduces the probability that insects, welding sparks or other particles lead to a shutdown of a plant.

If a multiple evaluation of 4 is configured, an object has to be detected 4 times in succession in the safety zone, so that the safety laser scanner switches the OSSDs to the OFF state.

With a multiple evaluation > 2 an allowance has to be made to the response time. The height of the allowance (see [Calculation of the overall response time](#) [32]) results from the value of the multiple evaluation and the valid response time (see [Technical details](#) [86]).

4.13 Monitoring of reference outlines

An outline within the area covered by laser beams can be defined and monitored in PSEnscan Configurator as a reference outline. The outline is formed from reference points.

When PSEN sc L 3/5 series detects a change of the outline, the safety laser scanner switches the OSSDs to the OFF state.

National and international standards recommend reference outlines for vertical applications to reliably detect changes in the installation position of the safety laser scanners. This may be changes due to vibration or changes due to manipulation of the safety laser scanner.

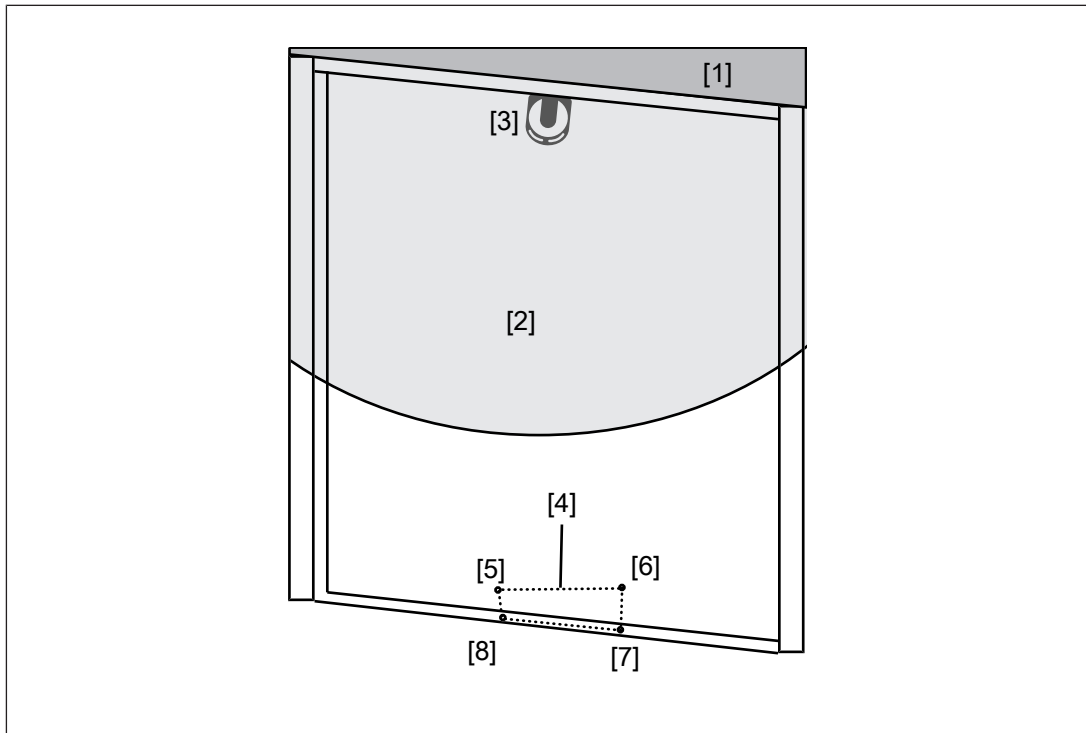

Fig.: Using of a reference outline on a passage

Legend

- [1] Danger zone
- [2] Monitored safety zone
- [3] Safety laser scanner
- [4] Reference outline from the reference points [5]-[8]
- [5]-[8] Reference points

4.14 Restore configuration

If you experience problems with the configuration, a failed firmware update or any other situation in which the system is no longer functional, it may be necessary to reset the system with a different configuration.

With this function, a configuration can be adopted for further systems and therefore simplify the configuration of further systems.

Typical applications for restoring a configuration:

- ▶ Configuration of further systems with a similar design
- ▶ Interrupting the supply voltage during the firmware update
- ▶ Forgotten password
- ▶ Incorrect configuration of the IP address

4.15 Examples of application

If a violation of the protective zone is detected, the evaluation device switches off the outputs configured for this. The machine is brought to a safe condition via the connected OSSDs.

If a violation of the warning zone is detected, the actions configured in PSENscan Configurator are performed. A visual or audible signal can be activated as advance warning.

When using 2 warning zones, different reactions can be configured.

4.15.1 Horizontal application

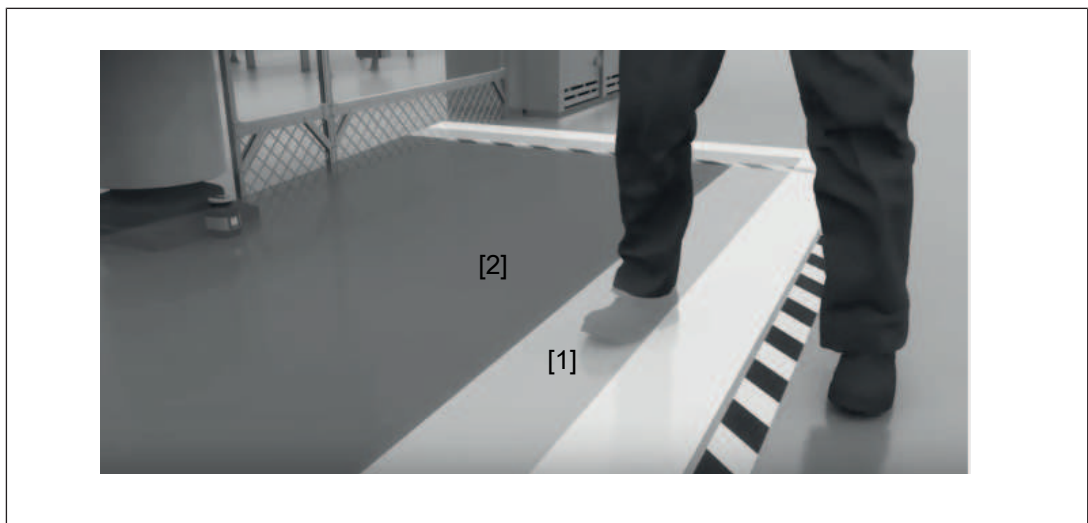

Fig.: Application example PSENscan safety laser scanner - horizontal configuration

Legend

[1] Warning zone

[2] Safety zone

4.15.2 Vertical application



Fig.: Application example PSENscan safety laser scanner - vertical configuration

Legend

[1] Protective zone

4.15.3 Mobile application

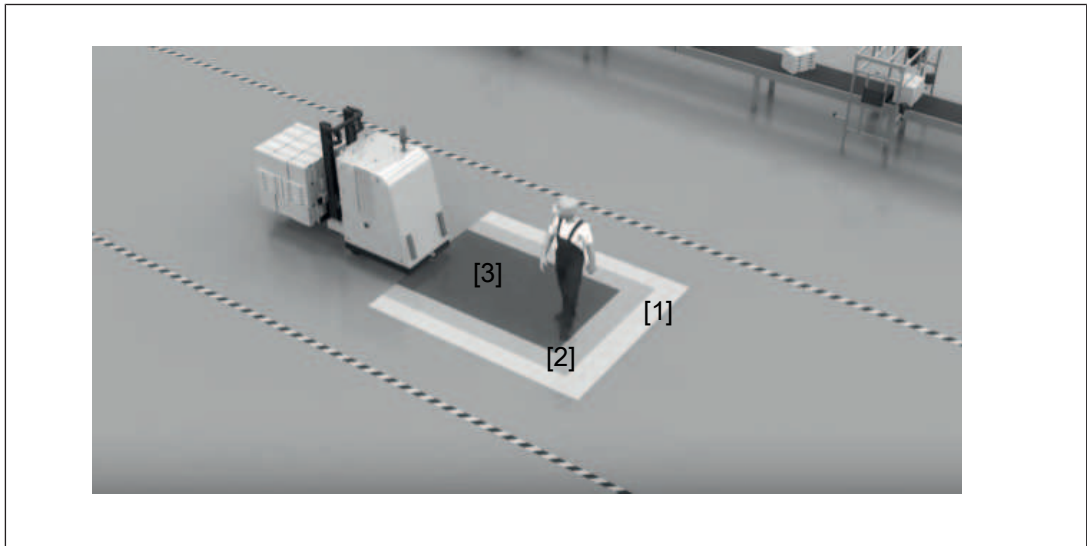

Fig.: Application example PSEnscan safety laser scanner - mobile configuration

Legend

- [1] Warning zone 1
- [2] Warning zone 2
- [3] Protective zone

The safety laser scanner scans the area in front of an automated guided vehicle system to prevent collisions. When an object or a person is detected, the safety laser scanner sends a signal to the automated guided vehicle system.

- ▶ When the warning zone is violated, an alarm of the automated guided vehicle system can be triggered. The person can leave the route or remove the object from the route.
- ▶ When the protective zone is violated, a stop of the automated guided vehicle is triggered.

5 Project configuration

5.1 Maintaining the safety distance

5.1.1 General

The minimum distance from the start of the protected area by the safety laser scanner to the hazardous machine component should be such that the operator cannot reach the danger zone until the movement of the hazardous machine part has stopped.

In accordance with the standard

- ▶ EN ISO 13855

this distance depends on the following factors:

- ▶ Overall response time of the safety laser scanner

Time between the interruption of the laser beam and the OSSDs' change to the OFF state (see [Calculating the overall response time](#) [ 32]).

- ▶ Machine's stopping time

Interval between the change of the OSSD to the OFF state and the stopping of the hazardous machine movement (including the reaction time of the connected relay)

- ▶ Approach speed

The speed with which the object to be detected is nearing the danger zone in mm/s

- ▶ Direction of approach

- Orthogonal = vertical application

The object to be detected approaches the danger zone at a right angle to the danger zone.

- Horizontal = horizontal application

The object to be detected approaches the danger zone in parallel to the danger zone.

- ▶ Reflection of the ambient light

- ▶ Preventing stepping behind/circumventing the safeguard

- Height of the scan plane
- Detection capability
- Switchover times

The general formula for calculating the minimum distance in accordance with EN ISO 13855 is:

$$S = (K * T) + C$$

S Minimum distance in mm, measured from the start of the protective zone to the danger source

K Approach speed at which the object (body) to be detected is nearing the danger zone in mm/s

T Overall time from the occurrence of a safety zone violation to the complete stop of the machine

The value is separated for the calculation in t_1 and t_2 , with $T = t_1 + t_2$.

- C The allowance depends on the height of the scan plane, the detection capability and the ambient light

5.1.2 Horizontal application with stationary danger zone

A horizontal application has been achieved when the safety laser scanner is aligned at an angle of max. 30° with the floor level.

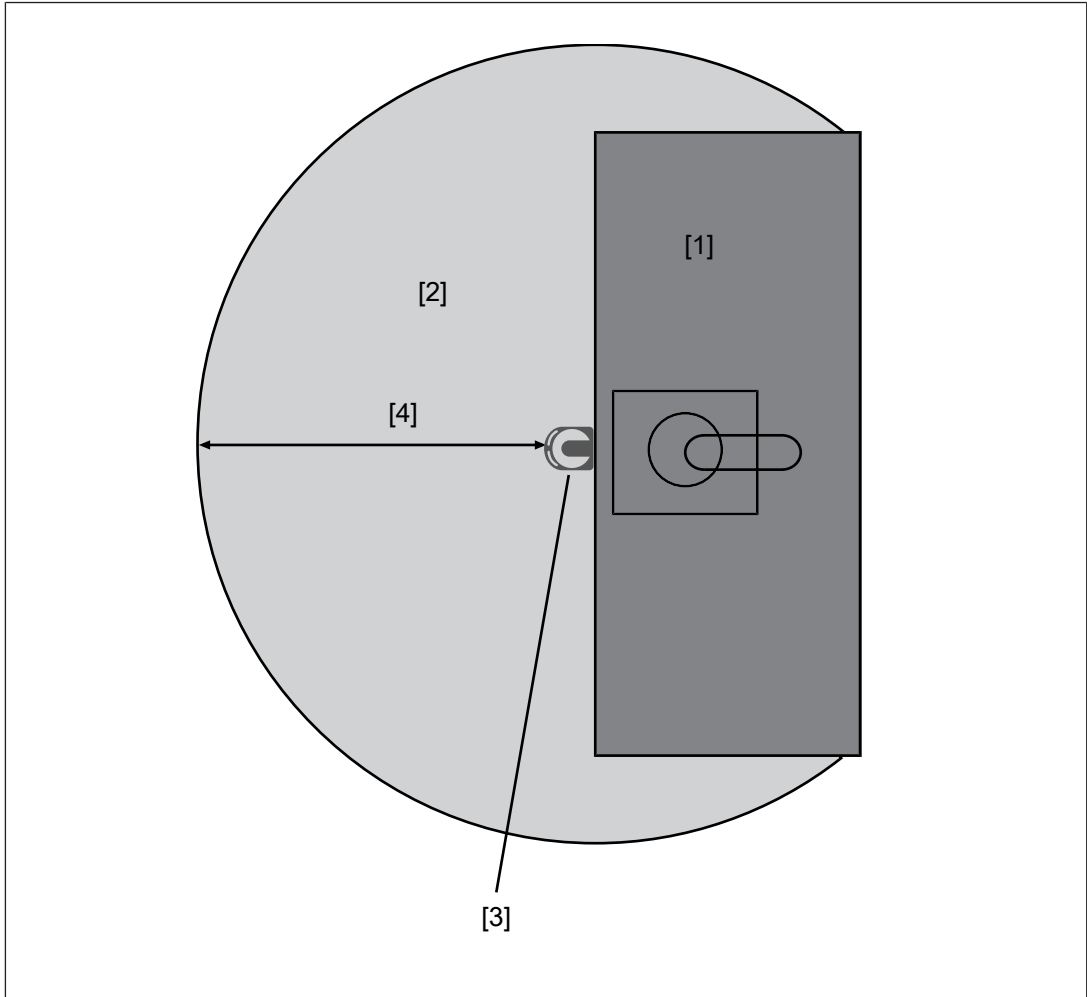

Fig.: Schematic representation minimum distance from the start of the protected area to the danger zone

Legend

- [1] Danger zone
- [2] Area covered by the laser beam
- [3] Safety laser scanner
- [4] Minimum distance to the danger zone (corresponds max. to the operating range of the safety laser scanner)

The following applies for these applications:

$$S = K * (t_1 + t_2) + Z_T + Z_R + C$$

S	Minimum distance in mm, measured from the start of the protective zone to the danger source
K	Approach speed with which the object to be detected is nearing the danger zone in mm/s $K = 1600 \text{ mm/s}$ when $S > 500 \text{ mm}$ $K = 2000 \text{ mm/s}$ when $S \leq 500 \text{ mm}$
t_1	Overall response time of the safety laser scanner in seconds (see Calculation of the overall response time [86]) Time between the violation of a protective zone and signal change at the OSSD output on the safety laser scanner
t_2	Machine's stopping time in seconds The time required for the machine to stop after the signal at the OSSD output changes
C	Additional distance depending on the height of the scanning plane and the detection capability
Z_T	General safety allowance = 100 mm
Z_R	Allowance when installing near intense light sources or reflective surfaces (see Distance to intense light sources and to reflective surfaces [86])

Determining the additional distance C depending on the height of the scanning plane and the detection capability (see EN ISO 13855)

$$C = (1200 - 0.4H)$$

Please note:

- ▶ Permitted height H of the scanning plane
 - $H \geq 15(d-50)$
 - $d = \text{Resolution}$ (see [Technical details \[86\]](#))
 - Max. 1000 mm
- ▶ When the safety laser scanner is to be placed at a height of $H > 300 \text{ mm}$, there is a risk of creeping underneath the safety zone. This is to be taken into account in the risk assessment, and if required additional protective measures must be taken.

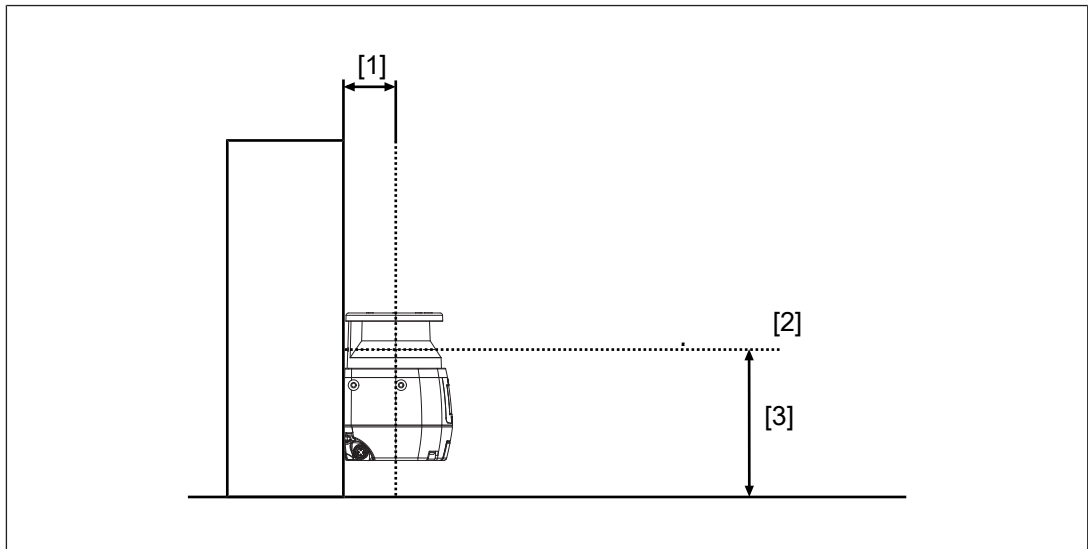

Legend

- [1] Opening between the origin of the laser beam of the safety laser scanner and the mounting area
- [2] Scanning plane
- [3] Height H between scanning plane and base area



CAUTION!

Risk of injury due to insufficient safeguard

Reaching into the opening between safety laser scanner and mounting area can lead to injuries.

- Prevent reaching into the opening by using a suitable safeguard.

5.1.3

Horizontal application with automated guided vehicle systems

The following applies for these applications:

$$S = S_{Br} + (T_{RtV} + t_1) * V_{max} + Z_T + Z_R + Z_F + Z_B$$

S	Minimum distance in mm, measured from the start of the protective zone to the danger source
---	---

S_{Br}	Braking distance of the automated guided vehicle system (AGV) (see Technical details of the AGV)
----------	--

T_{RtV}	Response time of the vehicle control system (see Technical details of the vehicle control system)
-----------	---

t_1	Overall response time of the safety laser scanner in seconds (see Calculation of the overall response time [32]) Time between the violation of a protective zone and signal change at the OSSD output on the safety laser scanner
-------	--

V_{max}	Maximum speed of the automated guided vehicle system (AGV) (see Technical details of the AGV)
-----------	---

Z _T	General safety allowance = 100 mm
Z _R	Allowance when installing near intense light sources or reflective surfaces (see Distance to intense light sources and to reflective surfaces [📖 34])
Z _F	Allowance for missing ground clearance (length of a foot)
Z _B	Allowance for decreasing braking power of the automated guided vehicle system (AGV) (10 %)

Please note:

► Height of the scan plane

Pilz recommends a scan plane height of 15 cm.

A person lying on the floor is detected. A lower height would lead to reduced availability because of the increased dust formation on the floor.

► If required, prevent the access to dead zone on the sides of the automated guided vehicle system by additional safeguards.

If this is not possible, the speed of the automated guided vehicle system must be limited to 0.3 m/s.

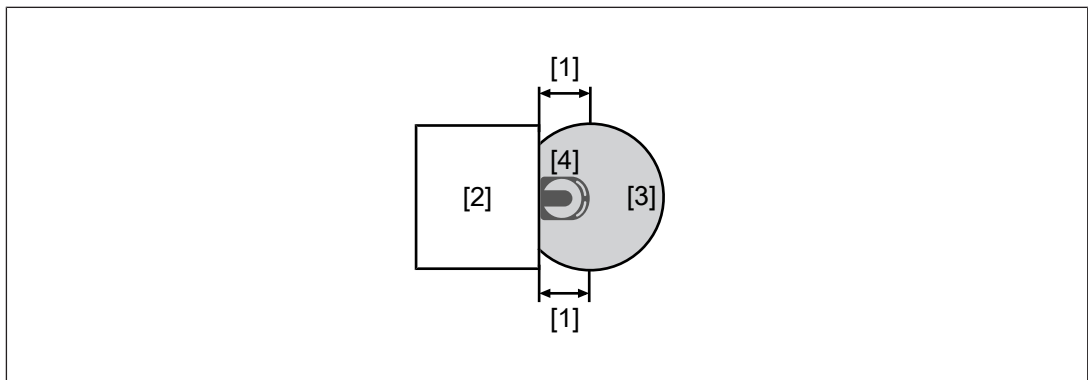

Fig.: Schematic representation of dead zones to the side of the automated guided vehicle system

Legend

- [1] Dead zones
- [2] Automated guided vehicle system
- [3] Area covered by the laser beam
- [4] Safety laser scanner



CAUTION!

Risk of injury due to insufficient safeguard

Reaching into the opening between safety laser scanner and mounting area can lead to injuries.

- Prevent reaching into the opening by using a suitable safeguard.

5.1.4 Vertical application

A vertical application is given if the safety laser scanner is aligned at an angle of min. 30° with the floor level.

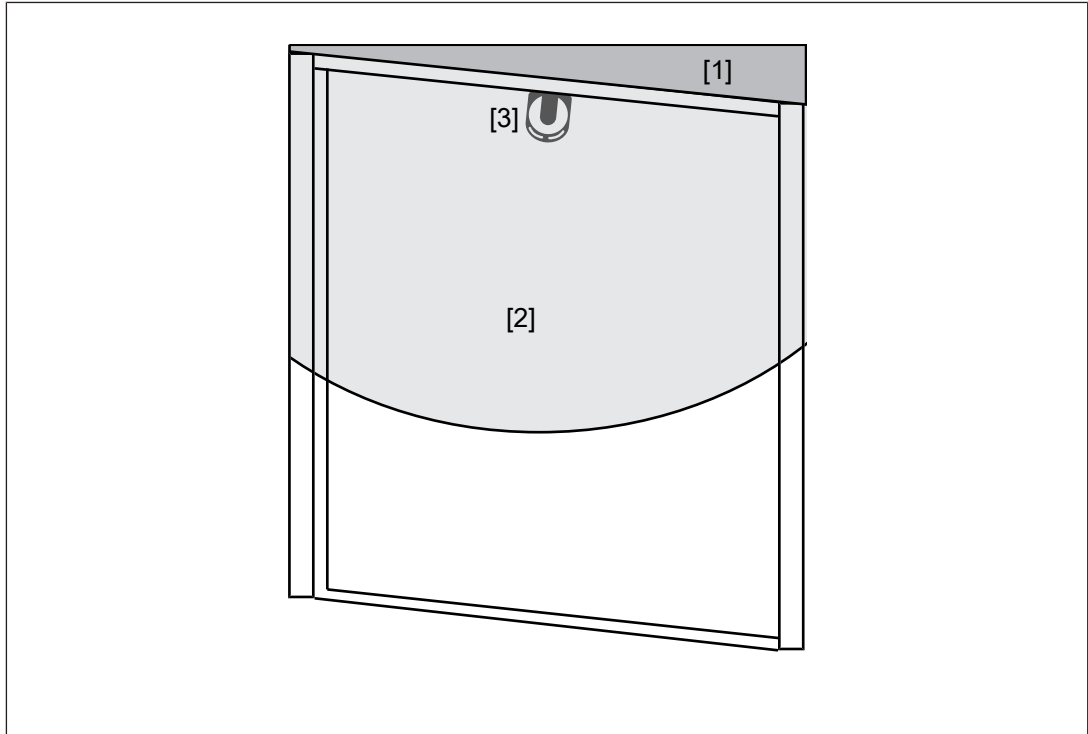

Fig.: Schematic representation of a vertical application on a passage

Legend

- [1] Danger zone
- [2] Area covered by the laser beam
- [3] Safety laser scanner

The following applies for these applications:

$$S = K * (t_1 + t_2) + Z_T + Z_R + C$$

S	Minimum distance in mm, measured from the start of the protective zone to the danger source
K	Approach speed with which the object to be detected is nearing the danger zone in mm/s $K = 1600 \text{ mm/s}$ when $S > 500 \text{ mm}$ $K = 2000 \text{ mm/s}$ when $S \leq 500 \text{ mm}$
t_1	Overall response time of the safety laser scanner in seconds (see Calculation of the overall response time [32]) Time between the violation of a protective zone and signal change at the OSSD output on the safety laser scanner
t_2	Machine's stopping time in seconds The time required for the machine to stop after the signal at the OSSD output changes

C	Additional distance depend on the detection capability d C = 8(d-14 mm) with d ≤ 40 mm C = 850 mm/s with d > 40 mm
Z _R	Allowance when installing near intense light sources or reflective surfaces (see Distance to intense light sources and to reflective surfaces [34])

5.2 Calculation of the overall response time

The overall response time results from the response time t_1 (see [Technical details \[86\]](#)), an allowance of 30 ms t_{multiple} for each scan > 2.

Overall response time T_{overall}

$$T_{\text{overall}} = t_1 + t_{\text{multiple}}$$

t_1	Response time t_1 (see Technical details [86])
t_{multiple}	Allowance 30 ms per rotation of the safety laser scanner (multiple evaluation > 2)

In a multiple evaluation = 3 the allowance is $T_{\text{multiple}} = 30 \text{ ms}$.

Each further increase of the multiple evaluation by 1 increases the allowance T_{multiple} by 30 ms.

5.3 Reference outline monitoring

To detect body parts in vertical applications, national and international standards recommend monitoring a reference outline.

The reference outline is configured during the first installation of PSEN sc L 3/5 series. The distances measured during configuration are used as reference values for monitoring the reference outline.

5.4 Area with limited detection capability

In the area of max. 100 mm before the laser scanner there is an areas with limited detection capability.

Please note:

- ▶ The area with limited detection capability must not be accessible for objects or persons.
- ▶ Install the safety laser scanner so that no objects can enter the zone with limited detection capability. Avoid installing the safety laser scanner below cable trays, so that cables cannot enter the area with limited detection capability.

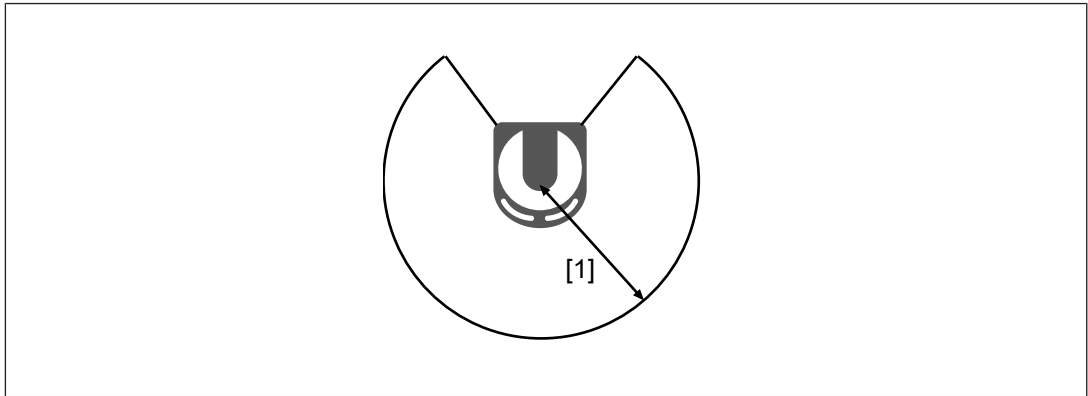

Legend

[1] Area with limited detection capability

5.5 Installation of several adjacent safety laser scanners

When safety laser scanners have to be installed in an area, it must be ensured that an interference between the safety laser scanners occur at a maximum for the duration of the double rotation time (see [Technical details \[86\]](#)).

This can be achieved by installing the safety laser scanner in various heights or inclination or by an opaque object between two laser scanners.

- ▶ Change the height of the safety laser scanners

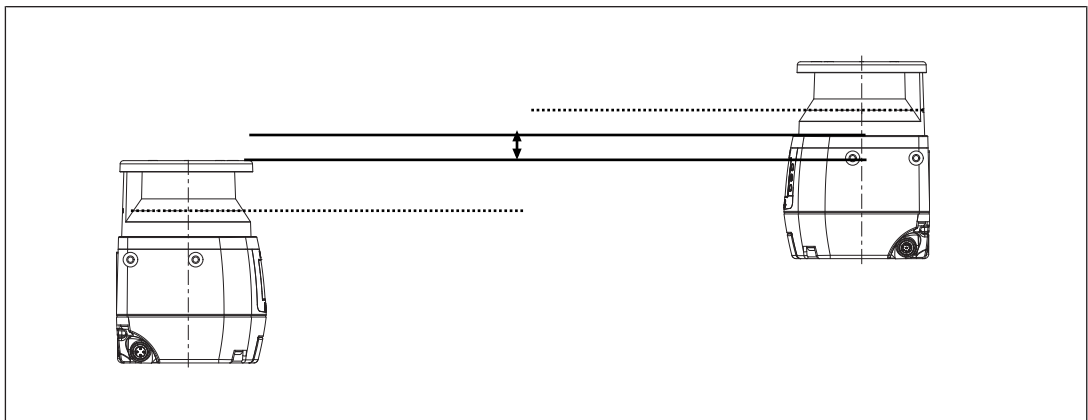

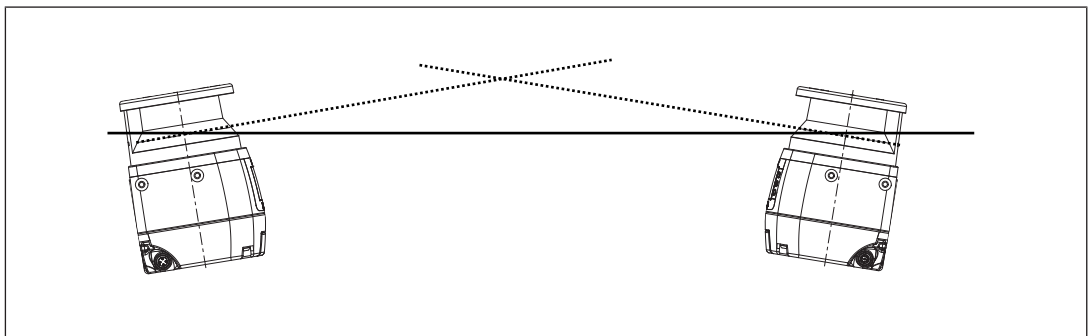

- ▶ Change the inclination of the safety laser scanners.

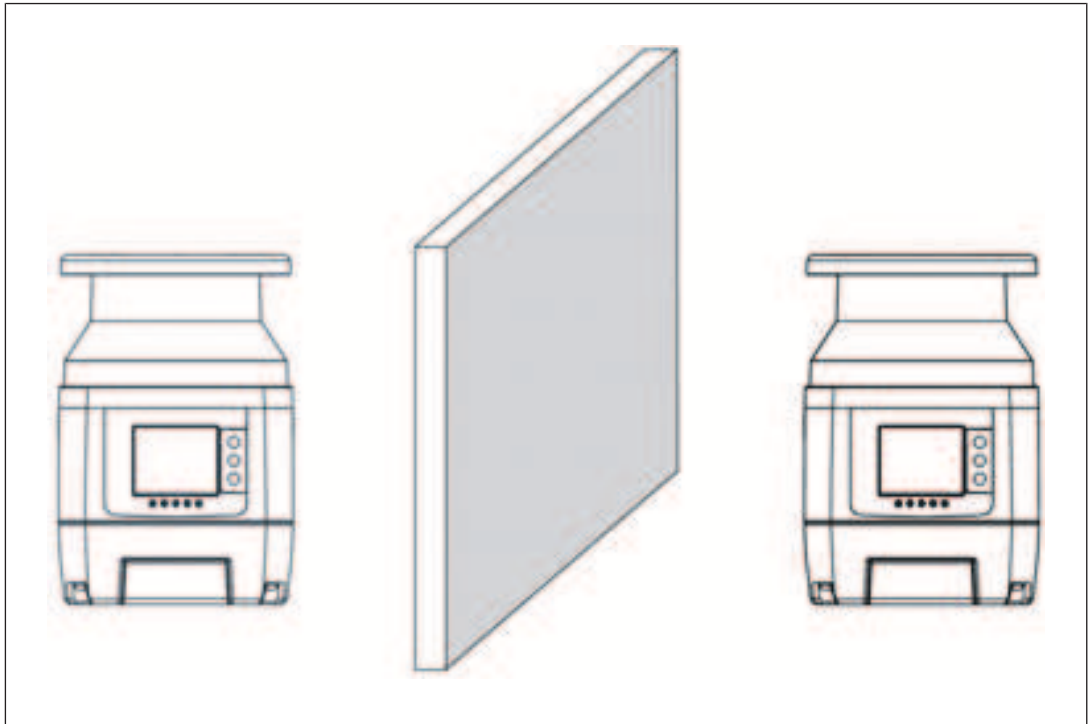

- ▶ Place an opaque object between the safety laser scanners



5.6 Ambient conditions

- ▶ Install the safety laser scanner in an environment that corresponds to the environmental data provided in the [Technical details](#) [ 86].
- ▶ If there is a highly reflective background within a distance of 2.5 m from the safety zone perimeter (e.g. a shiny metallic surface), errors in the calculation of the exact distance to the detected object may occur.
 - Reduce the reflection of the background or remove the background **or**
 - add the allowance Z_R to the minimum safety distance (see [Distance to intense light sources and to reflective surfaces](#) [ 34]).
- ▶ The transmitter of a safety laser scanner must not interfere with another safety laser scanner .
- ▶ Avoid strong electromagnetic interference when operating the safety laser scanner.
- ▶ When operating the safety laser scanner, avoid the development of smoke, mist, or dust that would reduce the safety laser scanner's range.

5.7 Distance to intense light sources and to reflective surfaces

Minimum distance to especially intense or flashing light sources

Pilz recommends that the safety laser scanner is not installed near particularly intense or flashing light sources.

When especially intense or flashing light sources are near the safety laser scanner (area of +/- 5° to the scanning plane, see figure), an allowance has to be considered when calculating the safety distance.

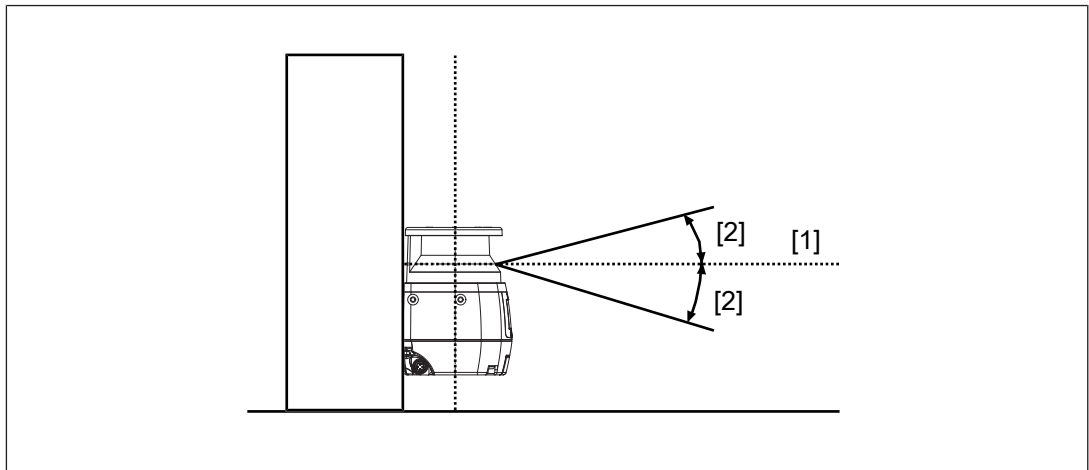

Legend

- [1] Scanning plane
- [2] Area of +/- 5° to the scanning plane

Minimum distance from reflective surfaces

If there are reflective surfaces near the laser beams emitted from the safety laser scanner (whether from above, below, or from the side), passive reflections can cause an object within the safety zone to remain undetected.

- ▶ Objects that may be influenced by safety laser scanners through ambient light, must not be placed within the opening angle of the laser beam.
- ▶ Pilz recommends that you install the safety laser scanner at a minimum distance of 2.5 m to reflective surfaces. (The recommendation was determined with a background reflection $\frac{cd}{300 \text{ m}^2 \cdot \text{lx}}$. For highly reflective backgrounds an additional safety assessment is required, taking into account the reflective background. This may result in a higher allowance.)

Allowance Z_R with distances below the recommended minimum distances to intense light sources or reflective surfaces

If the recommended distances cannot be met, the allowance Z_R must be considered when [calculating the safety distance](#) [27].

The value for the allowance Z_R depends on the selected level of the dust filter, on the selected detection capability and on the determined safety distance without this allowance.

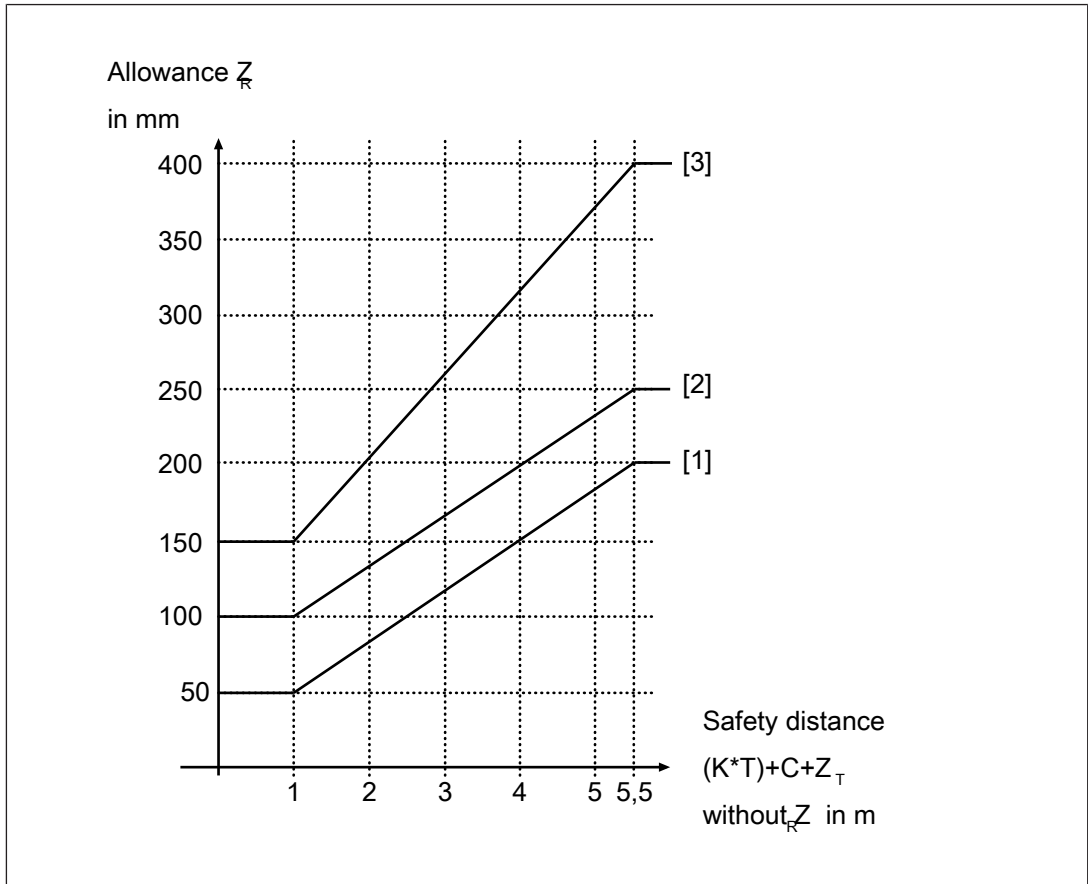

Fig.: Allowance with a detection capability of 70 mm

Legend

- [1] Low level
- [2] Medium level
- [3] High level

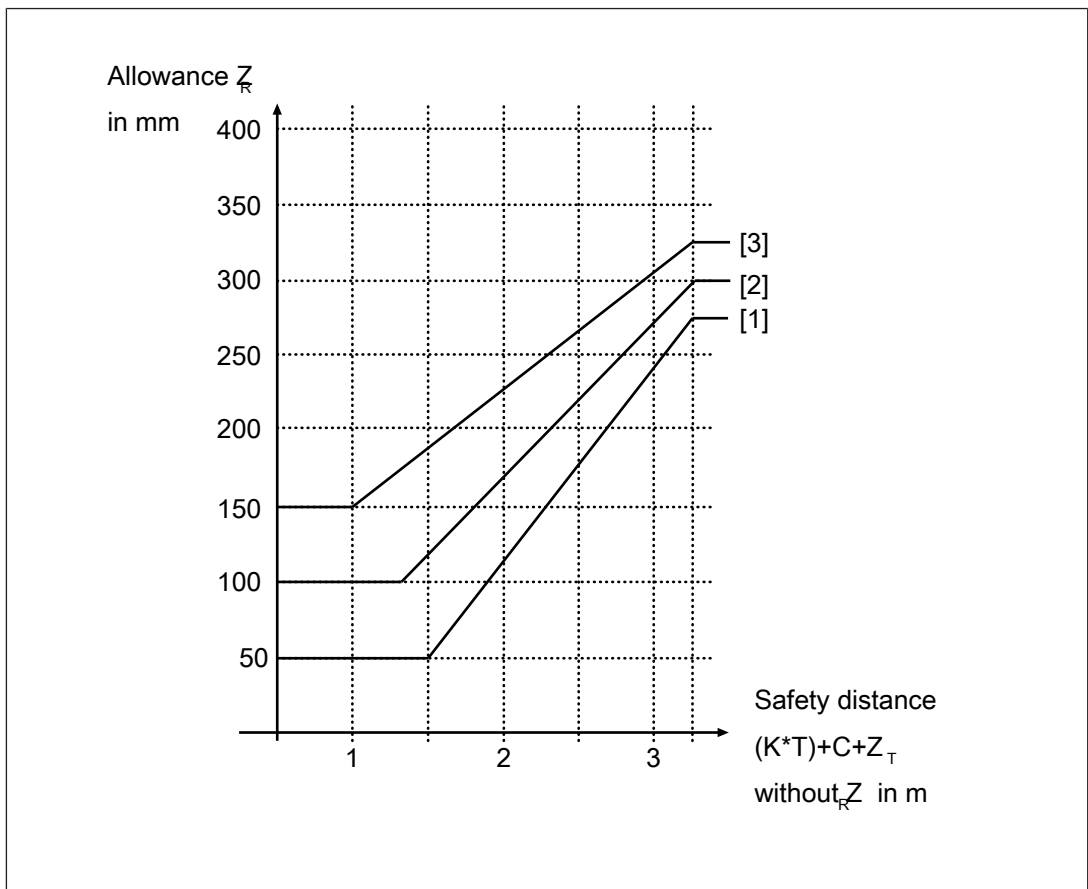

Fig.: Allowance with a detection capability of 40 mm

Legend

- [1] Low level
- [2] Medium level
- [3] High level



INFORMATION

Determining of the allowance when the safety laser scanner has to be installed near particularly intense or flashing light sources and a reflective background.

Use the higher value of the relevant allowances.

5.8 Distance from walls

The edges of the safety zone must have a distance of 40 mm to walls or fixed objects on all sides.

With this value, the function of the safety laser scanner is ensured. Depending on the reflective conditions of the walls or objects, higher allowances may be necessary (see [Distance to intense light sources and to reflective surfaces](#) [ 34]).



INFORMATION

Used value of the teach-in function for the distance to the walls

The PSEnscan Configurator teach-in function uses a value of 100 mm.

5.9 Planning of safety and warning zones and zone sets

- ▶ Specify the location and the size of the safety zone and the warning zone in accordance with the safety assessment.
- ▶ Specify in what situations the switching operation of the zone sets are to take place.

5.10 Switchover time with zone selection

The zone selection is done by digital signals that are controlled by the control system. For the changeover process a maximum switchover time (input delay in PSEnscan Configurator) is defined. For this time, non-permitted signals may be present at the entrances to the zone selection. After the switchover time has elapsed, a valid code for a zone must be present at the inputs for zone selection. The switchover time can be adjusted in increments of 30 ms, and it must be adapted to the performance of the control system.

Select the time where the control system can switch an input in a defined way.

5.11 Determining the moment of switchover



WARNING!

Risk of injury due to loss of the safety function by switching the monitoring too late

Switching the monitoring of zone sets too late results in the loss of the safety function. There may be people in the safety zone before switching.

- Use switching of monitoring in time or overlapping zone sets to ensure that no person is in the safety zone when this area changes to a danger zone.

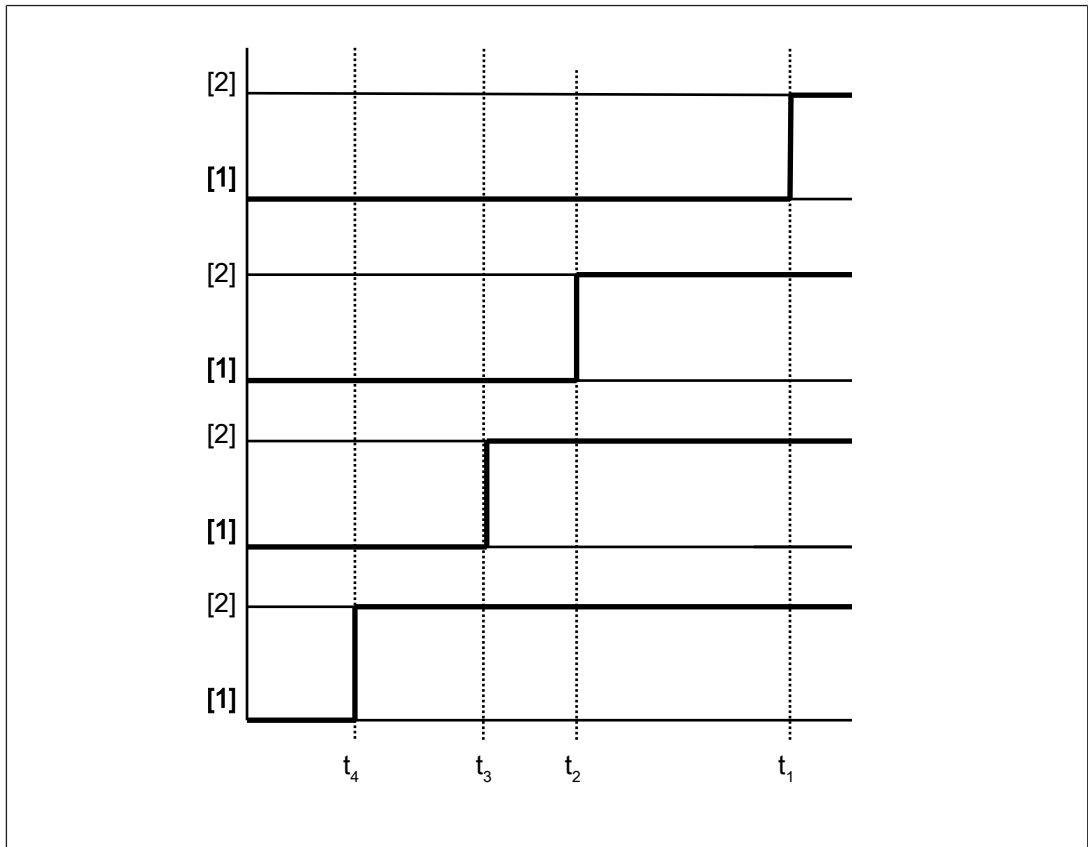

Legend

- t_1 Switchover time without advance
- t_2 Advance of the switchover time by the input delay
- t_3 Advance of the switchover time when using inputs of another device
- t_4 Advance of the switchover time when using inputs of external OSSDs
- [1] Monitoring zone set 1 is active
- [2] Monitoring zone set 2 is active

5.12 Dust filtration

The safety laser scanner has a dust filtration function. This changes the sensitivity of the safety laser scanner, and the availability in dusty environments can be improved.

There are three levels:

- ▶ High for high level of dust generation
- ▶ Average for medium level of dust generation
- ▶ Low of low level of dust generation



WARNING!

Loss of safety function due to a safety distance that is too low

Depending on the application, serious injury or death may result.

- ▶ Depending on the degree of dust filtering, it is necessary to consider an allowance for calculating the safety distance when installing the safety laser scanner near intense light sources or reflective surfaces into account (see [Distance to intense light sources and to reflective surfaces](#) [ 34]).
 - When calculating the safety distance, ensure that the allowance is considered depending on the dust filtering.
 - Ensure that the new safety distance fulfils the specifications of the safety assessment.

5.13 Muting

5.13.1 General

Please note:



CAUTION!

Risk of injury due to insufficient safeguard.

Accessing the danger zone can lead to injuries.

- Use an appropriate safeguard to prevent access to the danger zone.

Muting means a temporary suspension of the safety function. For this reason, the muting function must have a time restriction. When the muting sensors are activated and the muting state begins, an internal clock is started. If the muting sensors are still active after 10 minutes (status when delivered), the muting state is cancelled and the safety laser scanner switches to a safe condition.

The time monitoring of the muting function can be set in PSEnscan Configurator.



CAUTION!

Risk of injury due to loss of the safety function.

If time monitoring for the muting function is set to ∞ , the muting function is not cancelled until the muting sensors are no longer active.

This setting does not comply with the specifications of EN ISO 61496-1.

- Avoid a situation in which sustained muting is not detected.

- ▶ The muting state occurs,
 - when a sensor and the second sensor detect a conveyed material simultaneously or
 - When a sensor has detected a conveyed material and the second sensor also detects it max. 4 s afterwards.
- ▶ A muting activation is not possible when the safety laser scanner is in a safe condition (LED  lights up red, object detected in safety zone).
- ▶ Different conveyor speeds in the area of a PSEN sc L 3/5 series should be prevented.

5.13.2 Muting in one direction

Sequence of an L-muting cycle in accordance with flow of material

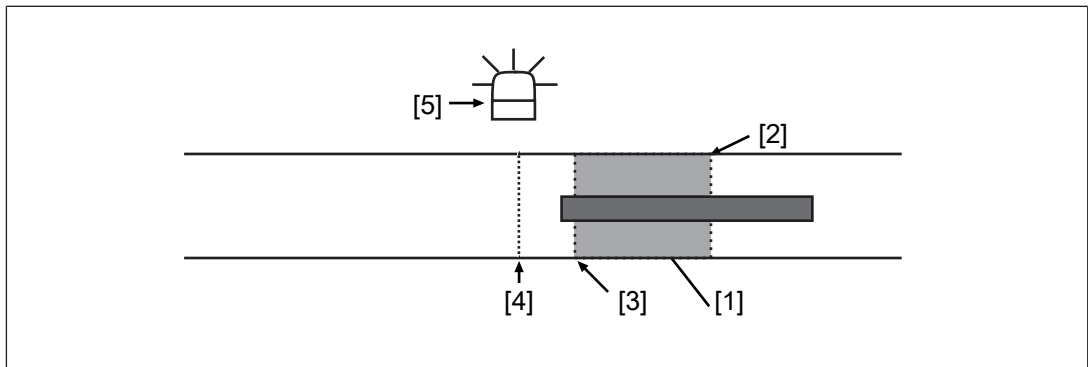

Legend

- [1] Conveyed material on conveyor
- [2] First muting sensor on the input side
- [3] Second muting sensor on the input side
- [4] PSEN sc L 3/5 series
- [5] Muting lamp

Please note the following distances and times when installing the safety laser scanner and using the muting function.

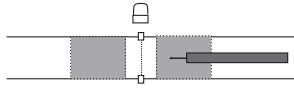
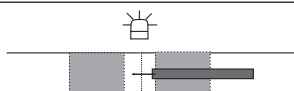
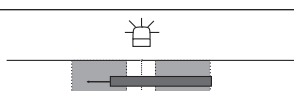
Phase in the muting cycle	Explanation
	Material has already passed the first muting sensor and is being transported on the conveyor in the direction of the second muting sensor, muting lamp off.
	Material on the conveyor passes the second muting sensor (max. 4 s after the first sensor was passed). Muting lamp flashes, signalling the muting state.
	Material on the conveyor passes the PSEN sc L 3/5 series and the first muting sensor on the output side, muting lamp flashes, signalling the muting state.

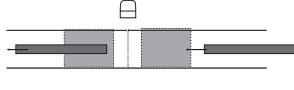
Phase in the muting cycle	Explanation
	<p>Material has left the area of the first muting sensor on the output side, muting lamp is off, muting state is ended.</p> <p>The next piece of material arrives at the first muting sensor.</p>

5.13.3 Muting in two directions

Sequence for T-muting cycle when material passes from the right-hand side

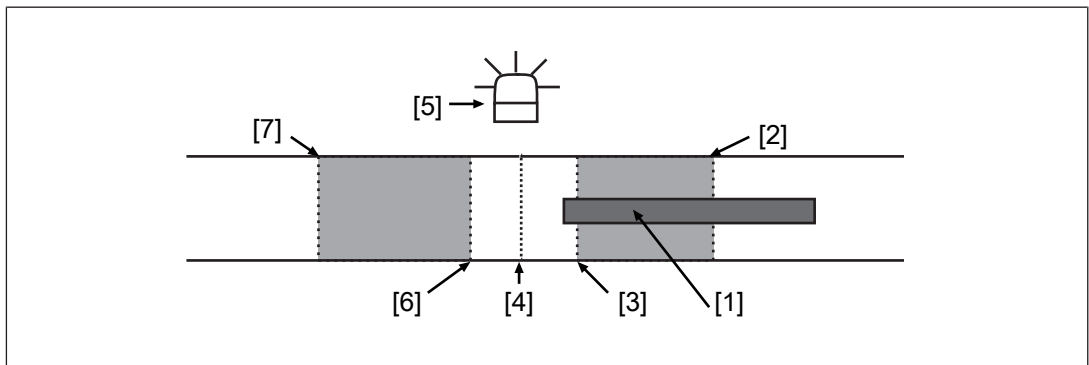

Legend

- [1] Conveyed material on conveyor
- [2] First muting sensor on the input side
- [3] Second muting sensor on the input side
- [4] PSEN sc L 3/5 series
- [5] Muting lamp
- [6] First muting sensor on the output side
- [7] Second muting sensor on the output side

Please note the following distances and times when installing the safety laser scanner and using the muting function.

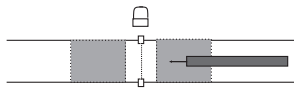
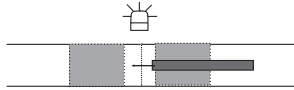
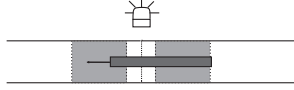
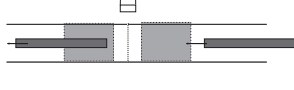
Phase in the muting cycle	Explanation
	<p>Material has already passed the first muting sensor and is being transported on the conveyor in the direction of the second muting sensor, muting lamp off.</p>
	<p>Material on the conveyor passes the second muting sensor (max. 4 s after the first sensor was passed). Muting lamp flashes, signalling the muting state.</p>
	<p>Material on the conveyor passes the PSEN sc L 3/5 series and the first muting sensor on the output side, muting lamp flashes, signalling the muting state.</p>
	<p>Material has left the area of the first muting sensor on the output side, muting lamp is off, muting state is ended.</p> <p>The next piece of material arrives at the first muting sensor.</p>

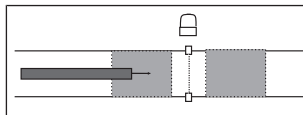

If material is transported from the left-hand side, the cycle is reversed. The output side becomes the input side and the flow starts with the second muting sensor on the output side.

5.13.4 Dynamic muting

When **Activate muting** is selected for one of the inputs 3, 9, 10 or 11, muting can be activated and deactivated dynamically.

► Conditions for the occurrence of muting

- One of the inputs 3, 9, 10 or 11 is connected to a controller and it receives a high signal from there when muting is to be activated
- When configuring the inputs, **Activate muting** is configured for this input in PSEnscan Configurator
- The first sensor has detected a conveyed material and the second sensor also detected it max. 4 s later **or** the first sensor and the second sensor detected conveyed material simultaneously

5.14 Override

The override function can be used for the three types according to the timing diagrams.

- Single-channel pulses
- Activation by rising edge
- Activation by rising signal (only when using the 12-pin connection)

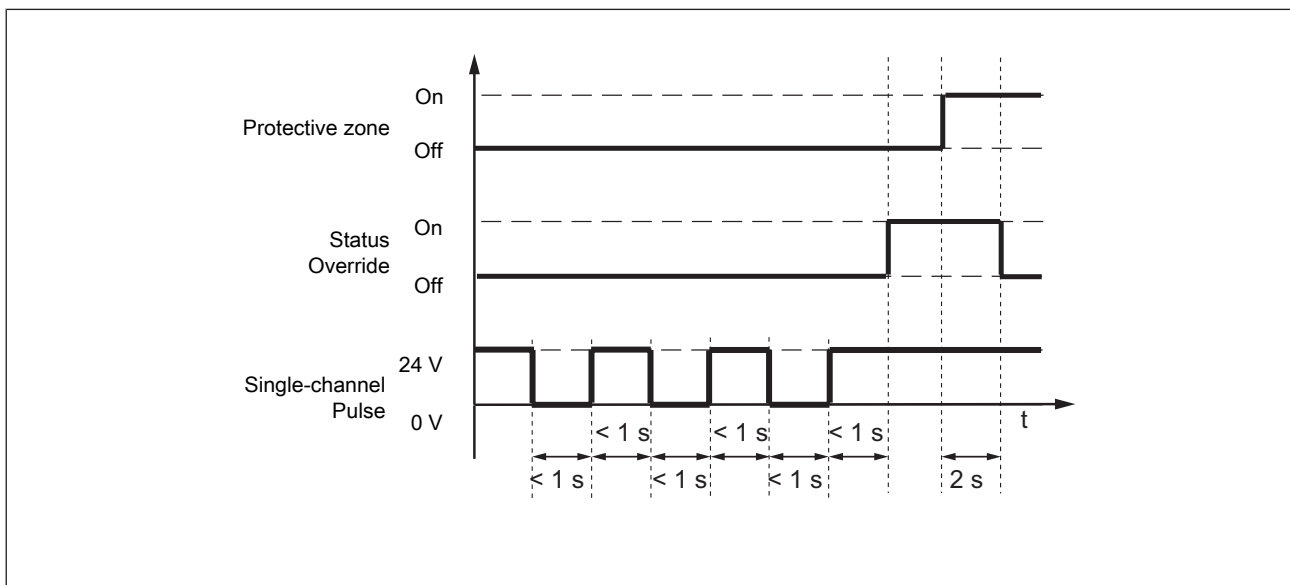

Fig.: Timing diagram for override function single-channel pulses

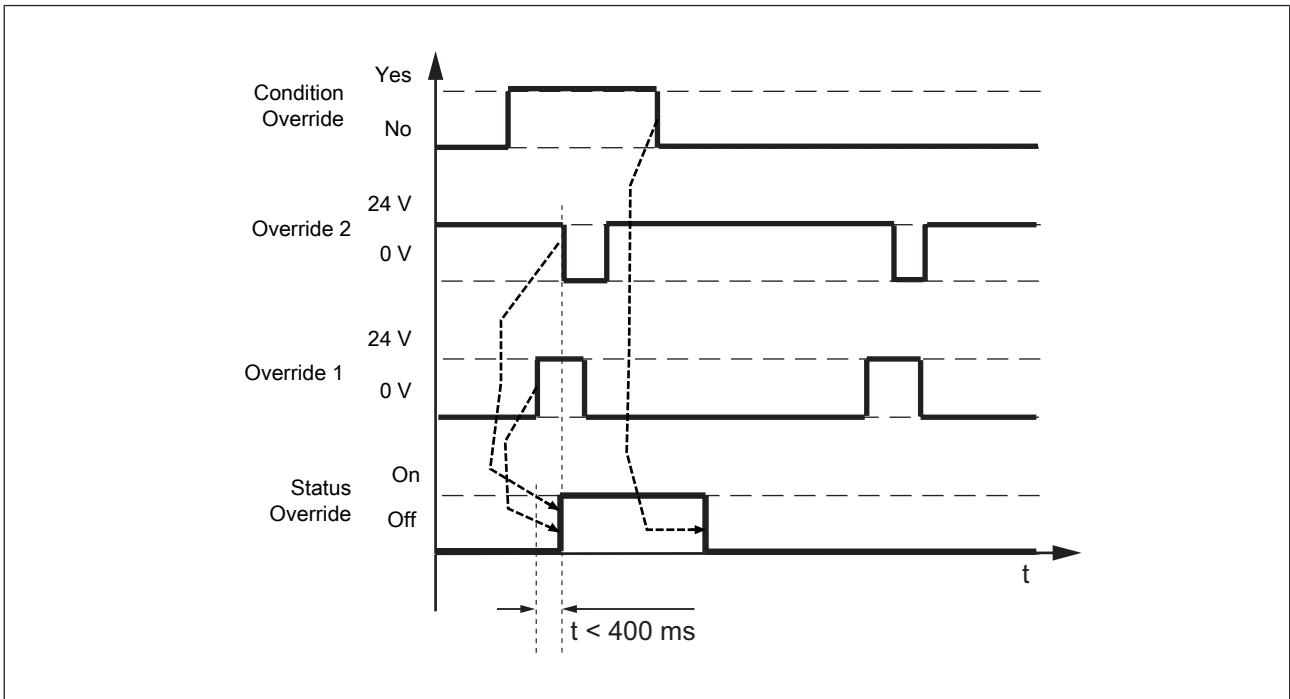

Fig.: Timing diagram for override function edge-triggered

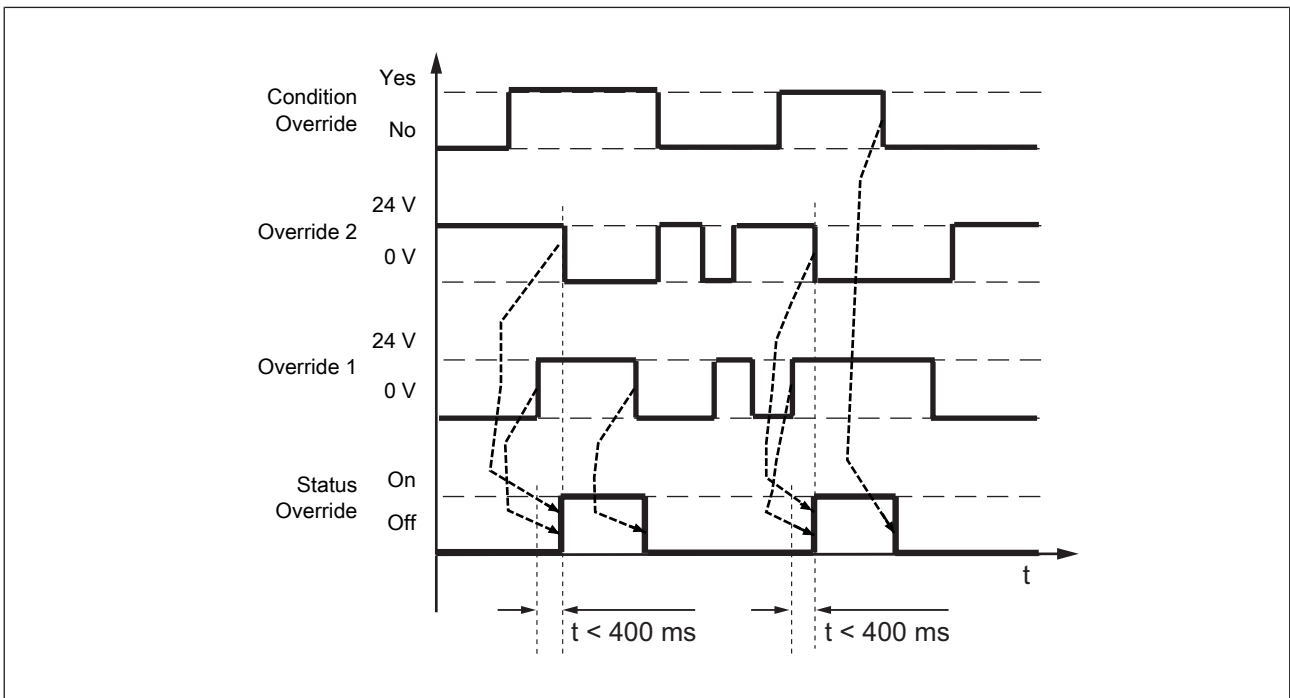

Fig.: Timing diagram for override function signal-triggered

6 Wiring

6.1 General guidelines

- ▶ Information given in the [Technical details \[86\]](#) must be followed.
- ▶ Do not lay the connecting cable near or in contact with cables that carry high or highly volatile currents.
- ▶ Use separate cables to connect the wires to the OSSDs of different safety laser scanners or safety switches.
- ▶ For supply voltage, use only PELV/SELV power supplies that have a voltage buffer in accordance with EN 60204-1.
- ▶ The protection type (see [Technical details \[86\]](#)) can only be achieved by using the Pilz connection leads available as an accessory.
- ▶ Connection to evaluation devices
 - Use the cables listed in the order reference (see [Order references for accessories \[91\]](#))
 - The clamps for connection to the evaluation device must be kept in a locked control cabinet. This prevents unauthorised modifications.
- ▶ Ensure compliance with permissible cable bending radii (see [Technical details \[86\]](#)).

6.2 Connector pin assignment

The safety laser scanner PSEN sc L 3/5 series has configurable inputs and outputs. In PSENscan Configurator these can be configured for the specific application.

The safety laser scanner PSEN sc L 3/5 series has an 8-pin male connector and a 12-pin male connector for connecting to the evaluation device and the supply voltage.

Use **one** of the two male connectors. The selected use has to be specified in PSENscan Configurator.

- ▶ Usage criteria of the 8-pin male connector
 - Two configurable inputs, one configurable input/output
 - Max. 3 zone sets
- ▶ Usage criteria of the 12-pin male connector
 - One configurable input, four configurable inputs/outputs
 - Max. 10 zone sets

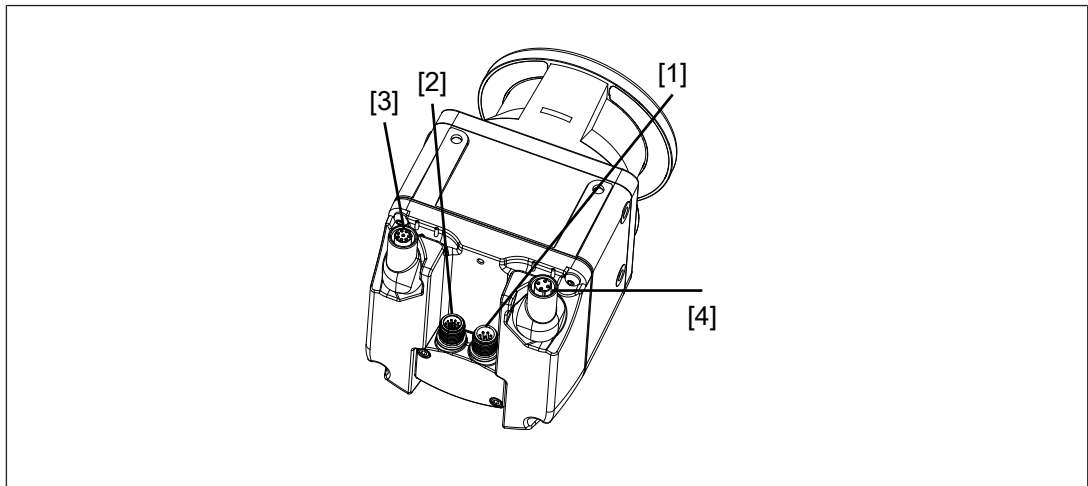

Legend

- [1] M12 8-pin male connector for connection to an evaluation device and the supply voltage
 - [2] M12 12-pin male connector for connection to an evaluation device and the supply voltage
 - [3] M12 4-pin female connector, hinged, for connection with a configuration PC
 - [4] M12 8-pin socket, hinged, not used
- M12 8-pin male connector for connection to an evaluation device and the supply voltage
- An OSSD pair
 - Two configurable inputs
 - One configurable input/output
 - Supply voltage
 - Functional earth

Pin/colour		Description
2	Brown	24 V DC
7	Blue	0 V DC
3	Green	Configurable input
4	Yellow	Configurable input
1	White	Configurable input/output
5	Grey	OSSD 1
6	Pink	OSSD 2
8	Red	Functional earth

- ▶ M12 12-pin male connector for connection to an evaluation device and the supply voltage
 - An OSSD pair
 - One configurable input
 - Four configurable inputs/outputs
 - Two inputs for supply voltage
 - Functional earth

Pin/colour		Description
1	Brown	24 V DC
4	Green	24 V DC
2	Blue	0 V DC
6	Yellow	0 V DC
3	White	Configurable input
7	Black	Configurable input/output
9	Red	Configurable input/output
10	Purple	Configurable input/output
11	Grey/pink	Configurable input/output
8	Grey	OSSD 1
5	Pink	OSSD 2
12	Red/blue	Functional earth

- ▶ M12 8-pin socket, hinged
 - not used
- ▶ M12 4-pin socket, hinged
 - Connection of the safety laser scanner to the configuration PC

The configurable inputs can be used for all input signals.

- ▶ Restart and reset
- ▶ EDM (when using the 12-pin connection)
- ▶ Switching the monitoring of zone sets
- ▶ Dynamic and static muting

The configurable inputs and outputs can be used for both input signals and output signals.

6.2.1 Configurable inputs

When using the 8-pin connection, the configurable inputs at PIN 3 and 4 can be used for the following functions:

- ▶ Restart
- ▶ Reset
- ▶ Restart or reset
- ▶ Zone set switching
- ▶ Muting 1 and 2
- ▶ Dynamic activation of the muting state

When using the 12-pin connection, the configurable input at PIN 3 can be used for the following functions:

- ▶ Restart
- ▶ Reset
- ▶ Restart or reset
- ▶ EDM
- ▶ Zone set switching
- ▶ Muting 1 and 2
- ▶ Dynamic activation of the muting state

6.2.2 Configurable inputs/outputs

When using the 8-pin connection, configurable input/output at PIN 1 can be used for the following functions:

- ▶ Warning output
- ▶ Alarms 1 or 2
- ▶ Muting lamp

When using the 12-pin connection, the configurable inputs/outputs at PIN 7, 9, 10 and 11 can be used for the following functions:

- ▶ Warning output
- ▶ Alarms 1 or 2
- ▶ Muting lamp

6.3 Wiring of the configurations

The configuration of the safety laser scanner PSEN sc L 3/5 series is carried out in PSENscan Configurator on a configuration PC.

The wiring has to match the specifications in PSENscan Configurator.

6.4 Connect supply voltage and safety controller

The connection for the supply voltage is underneath a memory module. The memory module can be uninstalled for simpler connection.

1. Turn the safety laser scanner PSEN sc L 3/5 series for better access to the memory module.
2. Loosen the M3 screws of the protective cover and remove the protective cover.
The screws are secured against loss and they cannot be removed.

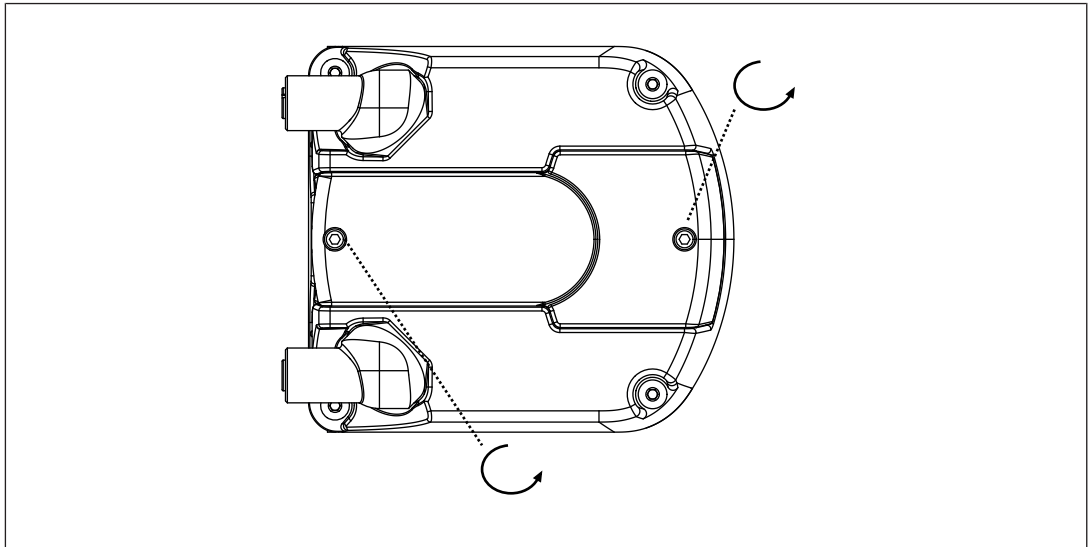

3. Loosen the M3 screws [1] of the memory module and pull out the memory module.
The screws are secured against loss and they cannot be removed.

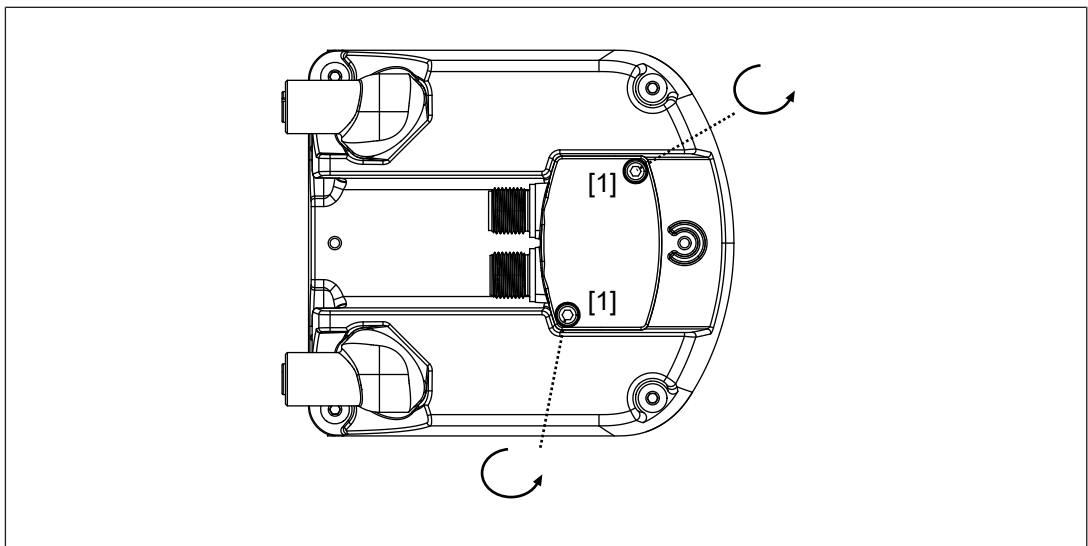

Legend

[1] M3 screws for fixing the memory module

4. Connect the supply voltage and the safety controller to the 8-pin or the 12-pin socket on the memory module.

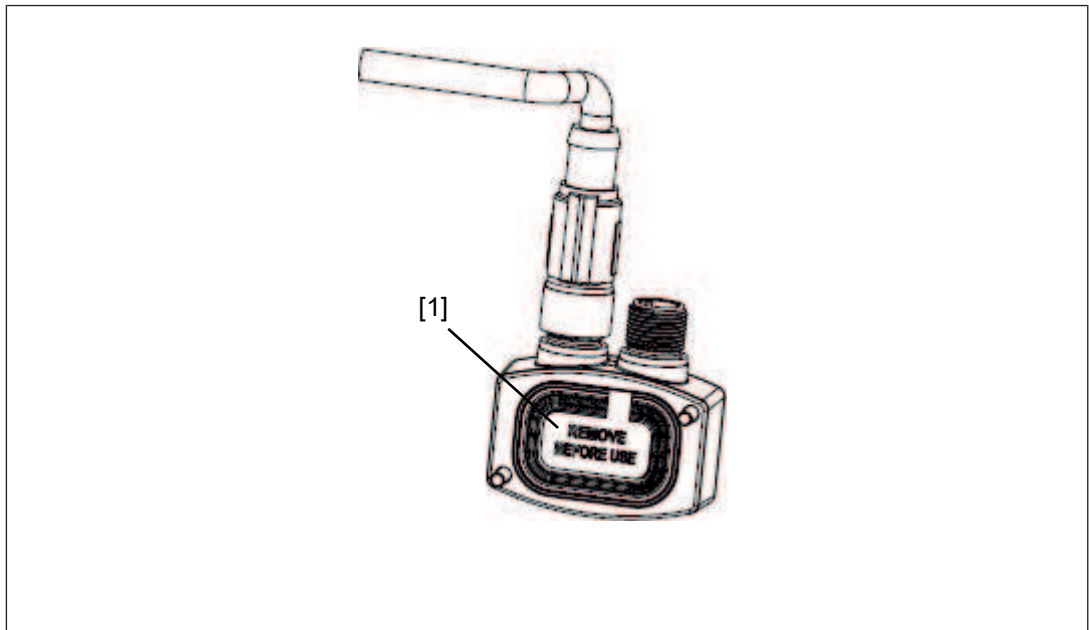

Legend

[1] Protective membrane

5. Remove the label [1] from the memory module and insert the memory module at the safety laser scanner.
6. Fix the screw of the memory module with a torque of 1 Nm.
7. Place the protective cover at the safety laser scanner and screw the protective covers with 1 Nm.

6.5 Connection to PSENscan Configurator

The configuration of the safety laser scanner PSEN sc L 3/5 series is carried out in PSENscan Configurator on a configuration PC.

Please note:

- ▶ Ensure that the software PSENscan Configurator is installed on the configuration PC.
- ▶ Ensure that the safety laser scanner is switched off when creating a connection to the configuration PC.

100BaseTX cable

Bit rate	100 MBit/s
Max. segment length	100 m
Medium	STP (shielded twisted pair) ^{*1} 2 pairs Category 5 ^{*2}
Connection	4-pin M12 male connector /4-pin RJ45 male connector
Topology	Point-to-point/hub (hub, switch)

^{*1}

For use in an industrial environment, Pilz recommends double-shielded twisted pair cables (S/STP). Only **shielded RJ45 connectors** should be used.

^{*2}

Twisted pair cables (TP cable) consist of twisted core-pairs. Twisted pair cables are divided into categories in accordance with their electrical features (attenuation, cross-talk). **Cat-egory 5 cables are specified** for transferring data with Pilz Ethernet interfaces.

TP cables for Ethernet applications generally have an impedance level of 100 Ohm.

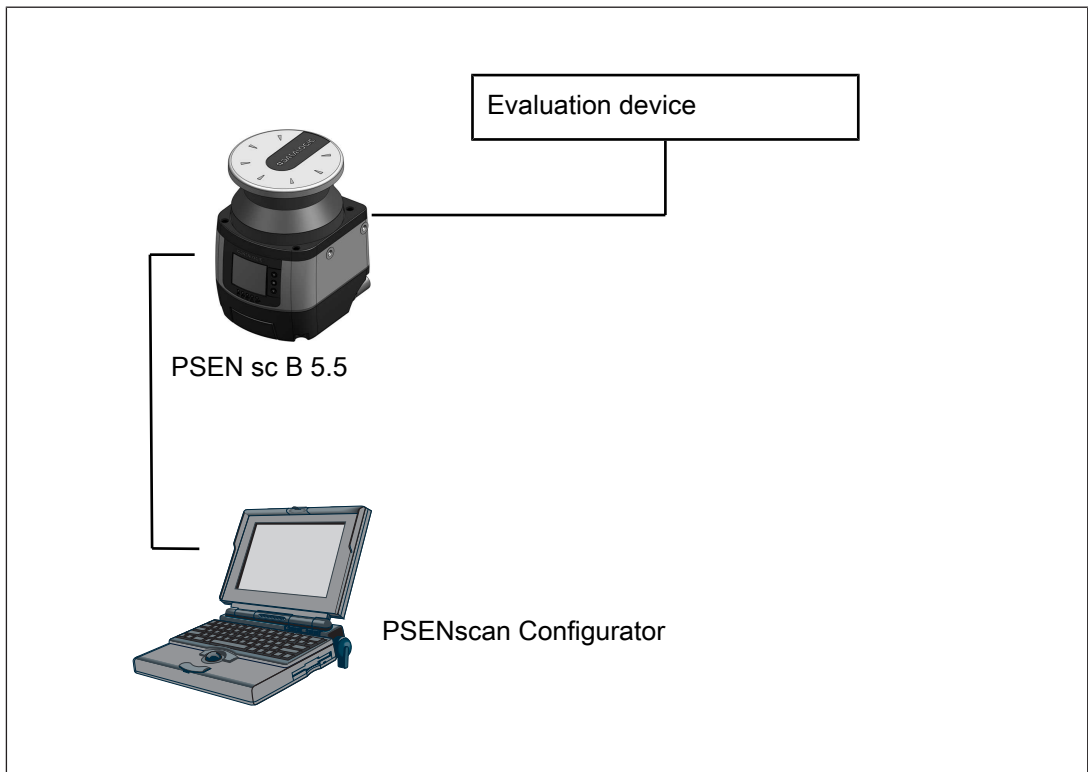

Procedure:

1. Use a 4-pin cable (see [Order references \[📖 91\]](#)) to connect the configuration PC to the safety laser scanner.
2. Use the safety laser scanner with an 8-pin cable (see [Order references \[📖 91\]](#)) with the supply voltage and an [evaluation device \[📖 65\]](#).

3. Switch the safety laser scanner on.
4. [Configure the safety laser scanner in PSEnscan Configurator.](#)  61]

6.6 Connections for muting sensors

Wire the muting sensors as shown in the following diagrams.

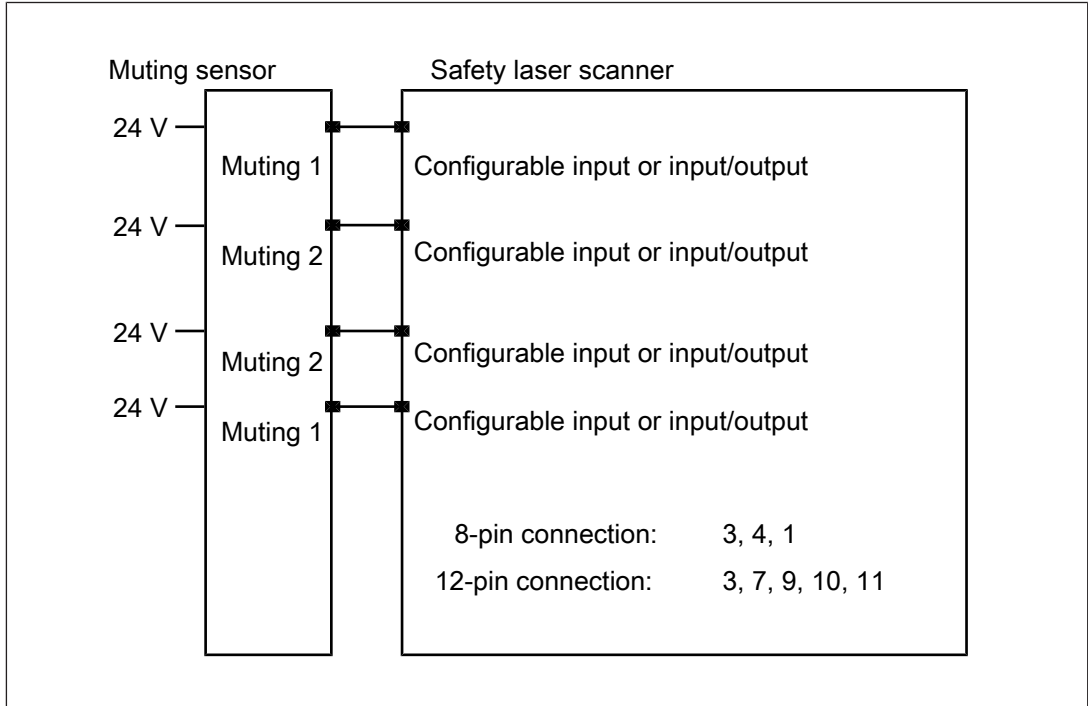

Fig.: Wiring of 4 muting sensors on PSEN sc L 3/5 series

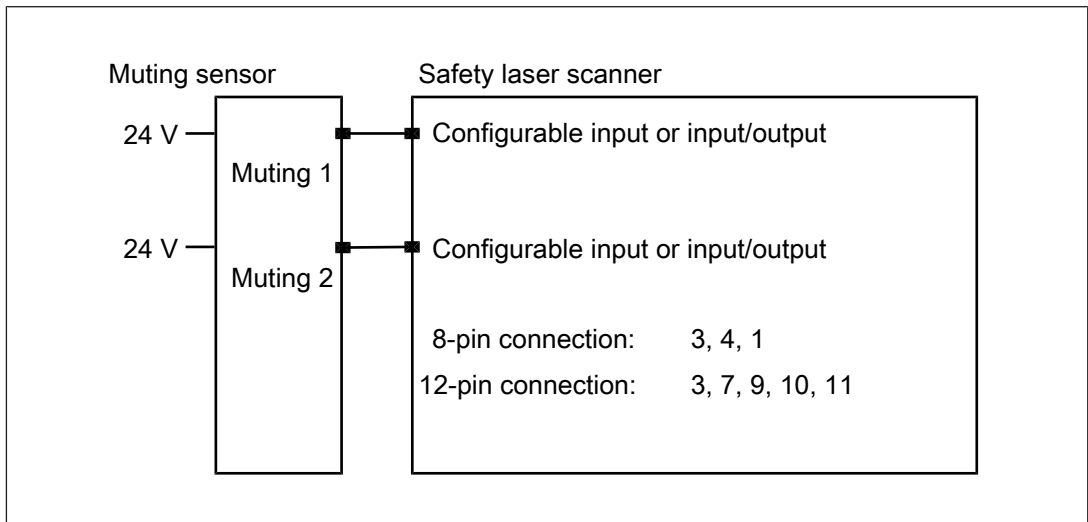

Fig.: Wiring of 2 muting sensors on PSEN sc L 3/5 series

7 Installation and alignment

7.1 Installation options

The safety laser scanner can be installed in various ways.

- ▶ Installation directly at the mounting surface [\[53\]](#)
- ▶ Installation with protective bracket PSEN sc bracket H [\[54\]](#)
- ▶ Installation with PSEN sc bracket PR for inclination to the side or to the top or bottom [\[55\]](#)
- ▶ Installation with PSEN sc bracket P for inclination to the top and bottom [\[57\]](#)

7.2 Installation without PSEN sc bracket H

For direct installation of the safety laser scanner at the mounting surface, two threaded holes are provided at the rear of the safety laser scanner.

Please note:

- ▶ With direct installation of the safety laser scanner at the mounting surface, the accessory PSEN sc bracket H cannot be used.
- ▶ With direct installation of the safety laser scanner at the mounting surface, the safety laser scanner cannot be inclined to the side or to the top/bottom.
- ▶ Ensure that the front panel of the safety laser scanners is not covered by a wall or another plane. Note the [distance to the walls \[38\]](#).
- ▶ To fix the safety laser scanner, use M5 screws for a max. screw depth of 10 mm.

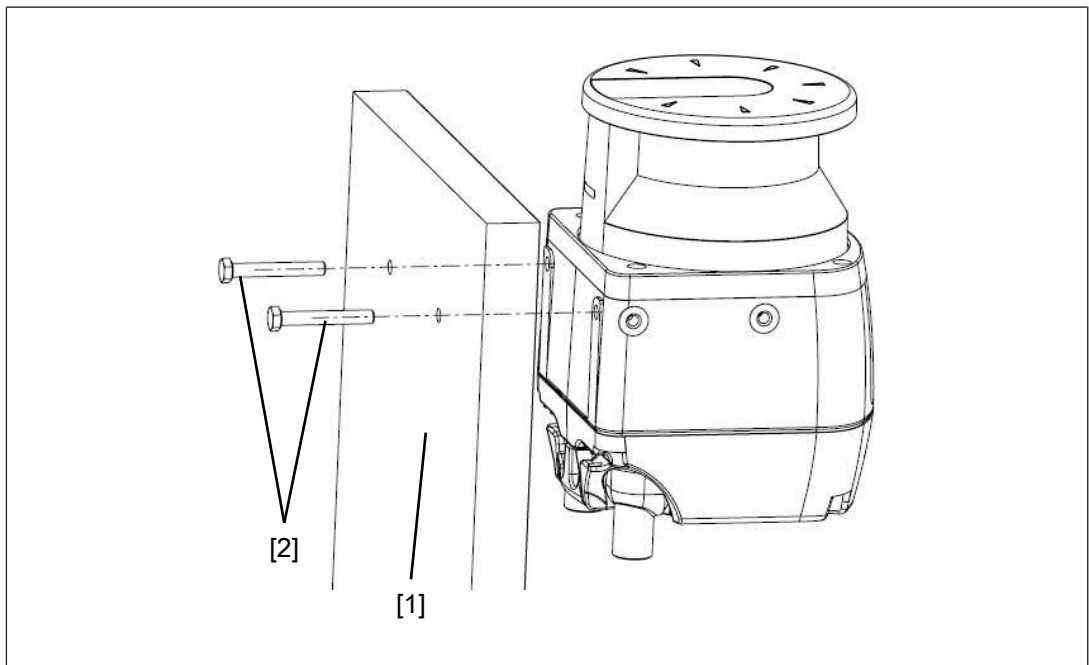

Legend

- [1] Mounting surface
- [2] M5 screws

Prerequisites

- ▶ Mounting surface with 2 through-holes for screws M5x10 mm, distance 73 mm horizontally towards each other for fixing the bracket of the safety laser scanner.
- ▶ The mounting surface has to be accessible from both sides for installation.

Procedure:

1. Turn the safety laser scanner when the safety laser scanner is to be operated with the top side down.
2. Use two M5 screws to fix the safety laser scanner to the mounting surface. Tighten the screws to 3 Nm.

7.3 Installation of the protective bracket PSEN sc bracket H at the safety laser scanner

For easy and flexible installation of the safety laser scanner, the safety laser scanner is fixed to a protective bracket PSEN sc bracket H (see [Order reference accessories \[91\]](#)). The protective bracket protects the safety laser scanner against damage by falling objects.

With this protective bracket the safety laser scanner can be used in both brackets PSEN sc bracket PR or PSEN sc bracket P (see [Order reference accessories \[91\]](#)).

1. Turn the safety laser scanner when the safety laser scanner is to be operated with the top side down.
2. Fix the PSEN sc bracket H at the rear of the safety laser scanner with two M5 screws and tighten both screws with 3 Nm.

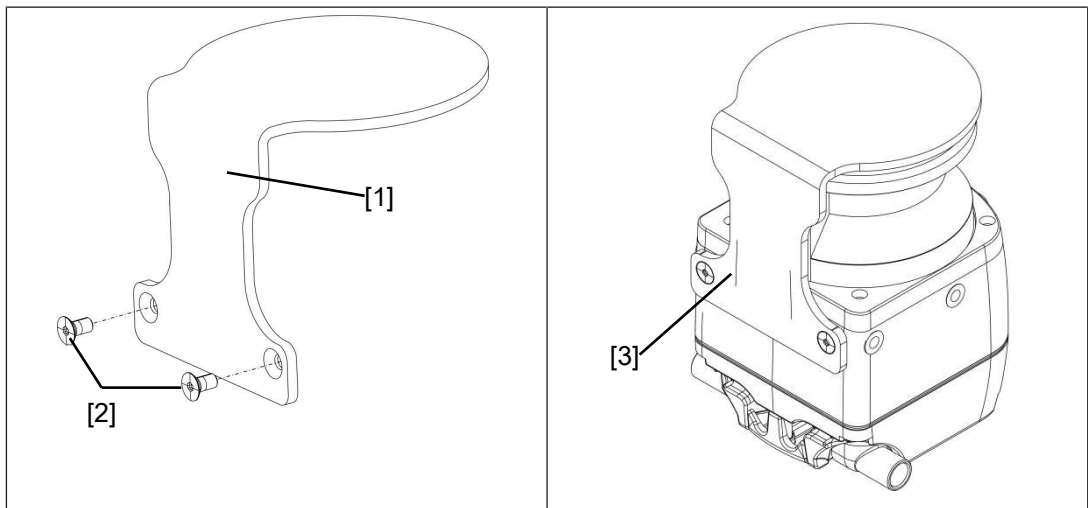

Legend

- [1] PSEN sc bracket H (protective bracket for safety laser scanner)
- [2] M5 screws for fixing the PSEN sc bracket H at the safety laser scanner
- [3] PSEN sc bracket H installed at the safety laser scanner

7.4 Installation with setting of angle of inclination/roll angle - bracket PSEN sc bracket PR

- ▶ The setting of the angle of inclination of the safety laser scanner is not changed when exchanging the safety laser scanner.

Prerequisites

- ▶ Mounting surface with 2 drill holes, 10 mm deep, distance 73 mm horizontally towards each other for fixing the PSEN sc bracket PR or PSEN sc bracket P
- ▶ The protective bracket PSEN sc bracket H must already be fixed at the safety laser scanner (see [Installation of the protective bracket PSEN sc bracket H at the safety laser scanner](#)  54).

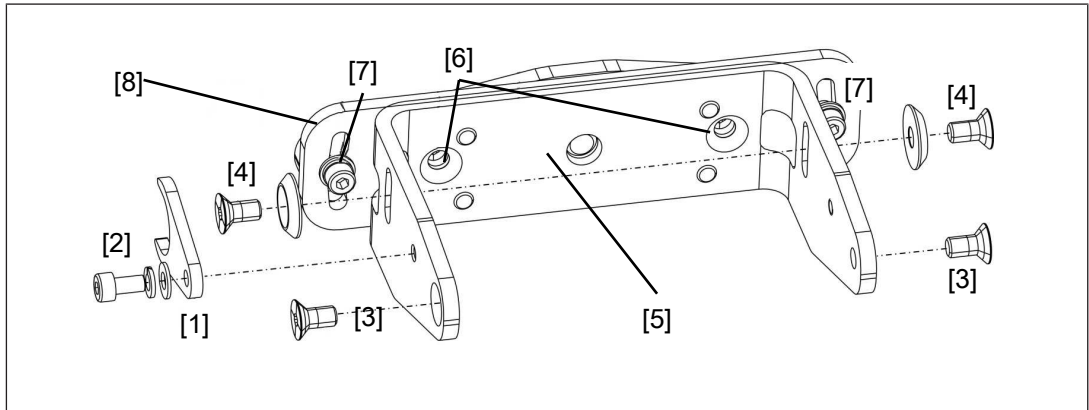

Legend

- [1] Adjusting disc for angle of inclination
- [2] Set screw for adjusting disc for angle of inclination
- [3] Fixing screws for safety laser scanner
- [4] Fine adjustment screws for the incline of the safety laser scanner
- [5] Front part of the PSEN sc bracket PR
- [6] Fixing screws for fixing to the mounting surface
- [7] Roll angle fine adjustment screws
- [8] Rear part of the PSEN sc bracket PR

Procedure:

1. Loosen the roll angle fine adjustment screws [7] of PSEN sc bracket PR slightly, if required, and align the front part [5] of PSEN sc bracket PR to the rear part [8].
The bracket is pre-assembled.
2. Fix PSEN sc bracket PR with the fixing screws [6] to the mounting surface and tighten the fixing screws [6] alternately and evenly with 3 Nm.
3. Fix the adjusting disc for angle of inclination [1] with the set screw and washers [2] at PSEN sc bracket P (right or left).
4. Align the middle of the adjusting disc for angle of inclination [1] with the center of the fixing for the safety laser scanner [3] and tighten the set screw for the adjusting disc for angle of inclination [2] with 2,5 Nm.

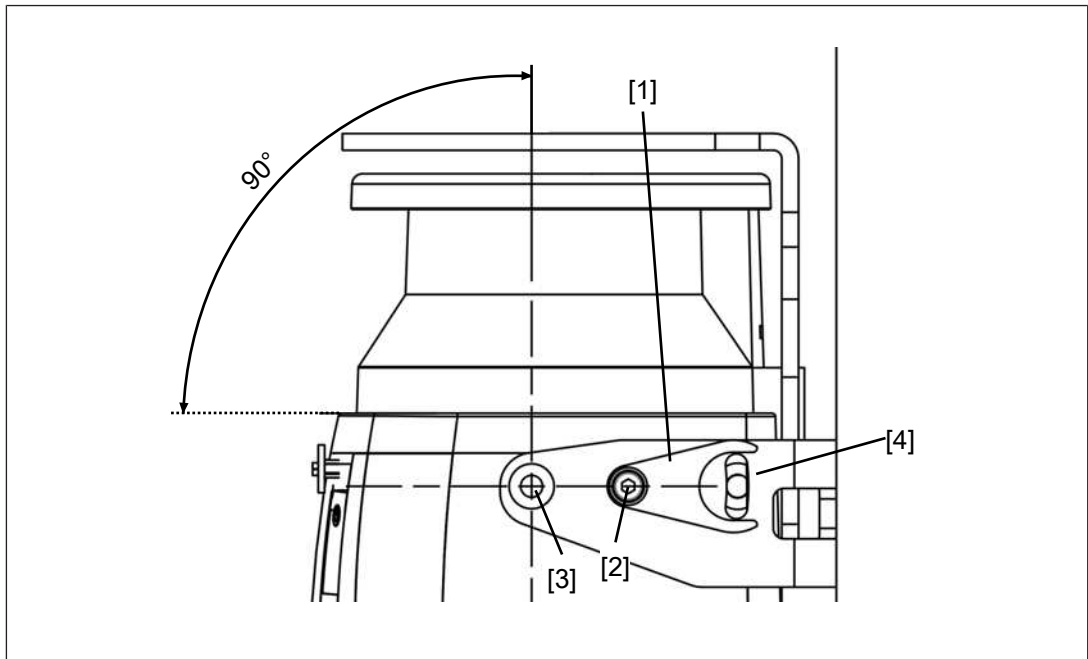

Legend

- [1] Adjusting disc for angle of inclination
 - [2] Set screw for the adjusting disc for angle of inclination
 - [3] Fixing screws for safety laser scanner
 - [4] Fine adjustment screws for the incline of the safety laser scanner
5. Insert the safety laser scanner in PSEN sc bracket PR with the bracket PSEN sc bracket H to the top and fix the safety laser scanner with the screws [3] and [4]. Tighten all four screws to 3 Nm.

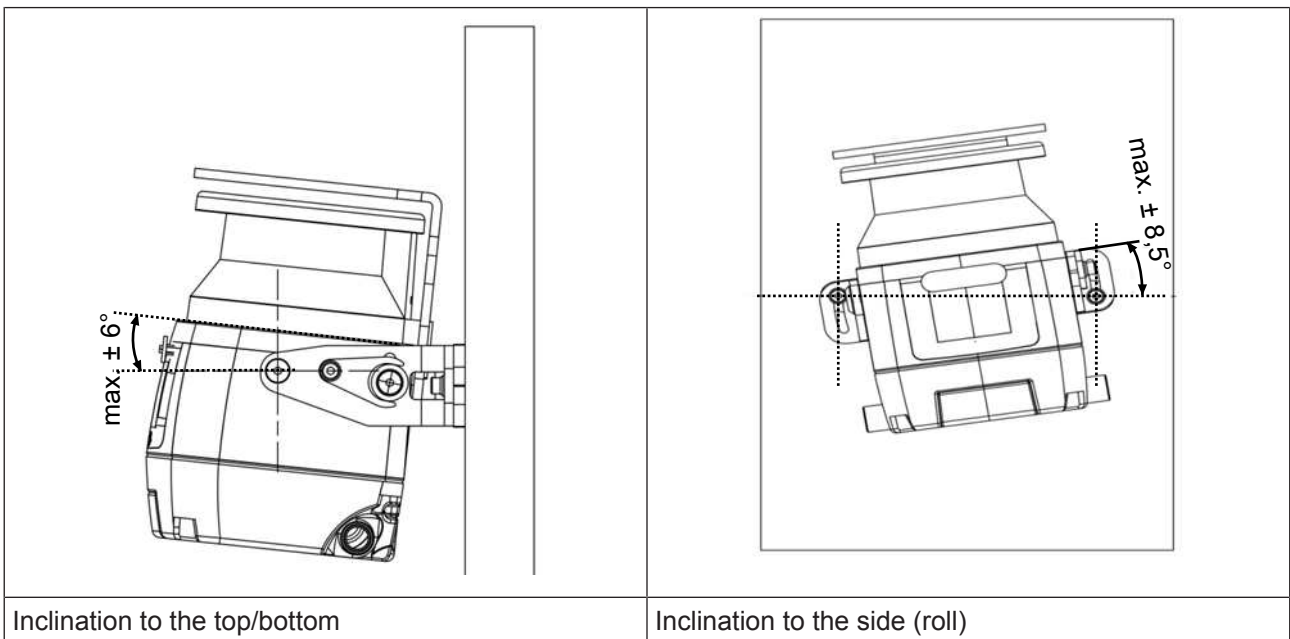

7.5 Installation with angle of inclination setting - holder PSEN sc bracket P

- ▶ The setting of the angle of inclination of the safety laser scanner is not changed when exchanging the safety laser scanner.

Prerequisites

- ▶ Mounting surface with 2 drill holes, 10 mm deep, distance 73 mm horizontally towards each other for fixing the PSEN sc bracket PR or PSEN sc bracket P
- ▶ The protective bracket PSEN sc bracket H must already be fixed at the safety laser scanner (see [Installation of the protective bracket PSEN sc bracket H at the safety laser scanner](#) [ 54]).

Procedure:

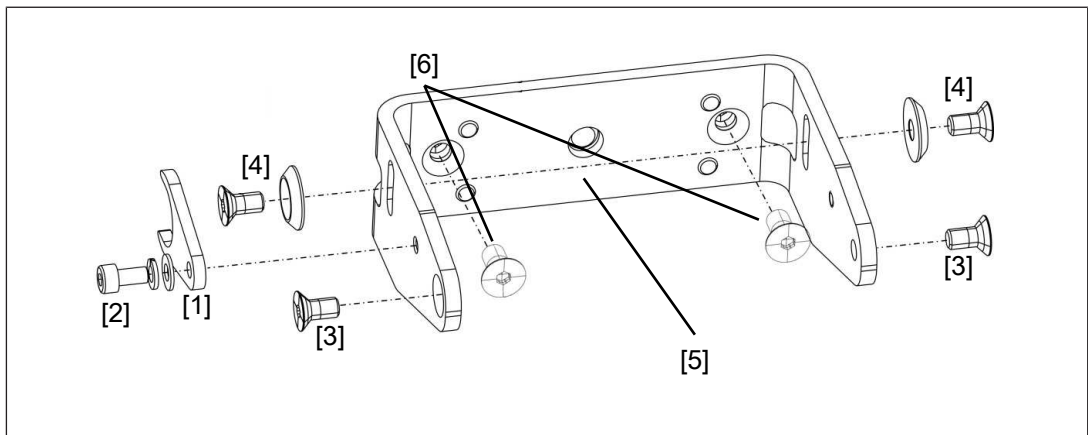

Legend

- [1] Adjusting disc for angle of inclination
- [2] Set screw for adjusting disc for angle of inclination
- [3] Fixing screws for safety laser scanner
- [4] Fine adjustment screws for the incline of the safety laser scanner
- [5] PSEN sc bracket P
- [6] Fixing screws for fixing to the mounting surface

Procedure:

1. Fix PSEN sc bracket P with the fixing screws [6] to the mounting surface and tighten the fixing screws [6] alternately and evenly with 3 Nm.
2. Fix the adjusting disc for angle of inclination [1] with the set screw and washers [2] at PSEN sc bracket P (right or left).
3. Align the middle of the adjusting disc for angle of inclination [1] with the center of the fixing for the safety laser scanner [3] and tighten the set screw for the adjusting disc for angle of inclination [2] with 2,5 Nm.

7.6 Set the angle of inclination of the safety laser scanner

Procedure:

1. Change the inclination of the safety laser scanner within the permitted range of $\pm 6^\circ$.
If necessary, loosen the fixing screws for the safety laser scanner [3], the fine adjustment screws for the inclination of the safety laser scanner [4] and the set screw for the adjusting disc for angle of inclination [2].

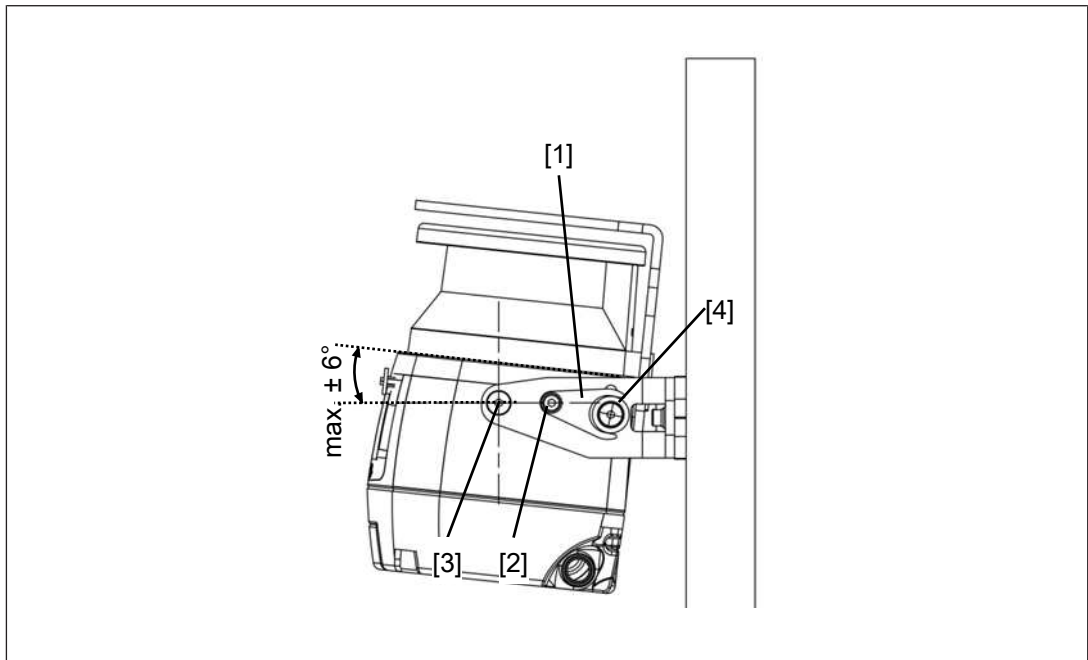

Legend

- [1] Adjusting disc for angle of inclination
 - [2] Set screw for adjusting disc for angle of inclination
 - [3] Fixing screws for safety laser scanner
 - [4] Fine adjustment screws for the incline of the safety laser scanner
2. Tighten the fixing screws for the safety laser scanner [3] with 3 Nm and tighten the fine adjustment screws for the inclination of the safety laser scanner [4].
 3. Tighten the set screw for the adjusting disc for angle of inclination [2] with 2,5 Nm.

7.7 Set the side inclination of the safety laser scanner

Prerequisites

- ▶ The bracket PSEN sc bracket PR has to be installed at the mounting surface.

Procedure:

1. Change the side inclination of the safety laser scanner within the permitted range of $\pm 8.5^\circ$.
If required, loosen the roll angle fine adjustment screws [7] (see figure [Installation with setting of angle of inclination/roll angle - bracket PSEN sc bracket P](#) [55]).
2. Tighten the roll angle fine adjustment screws [7] (see figure [Installation with setting of angle of inclination/roll angle - bracket PSEN sc bracket P](#) [55]) with 2,5 Nm.

7.8 Measures to safeguard unsecured areas

When installing the PSEN sc L 3/5 series areas may result that are not detected by the safety laser scanner.

If required, install additional protective devices to safeguard the danger zone.

Prevent stepping behind

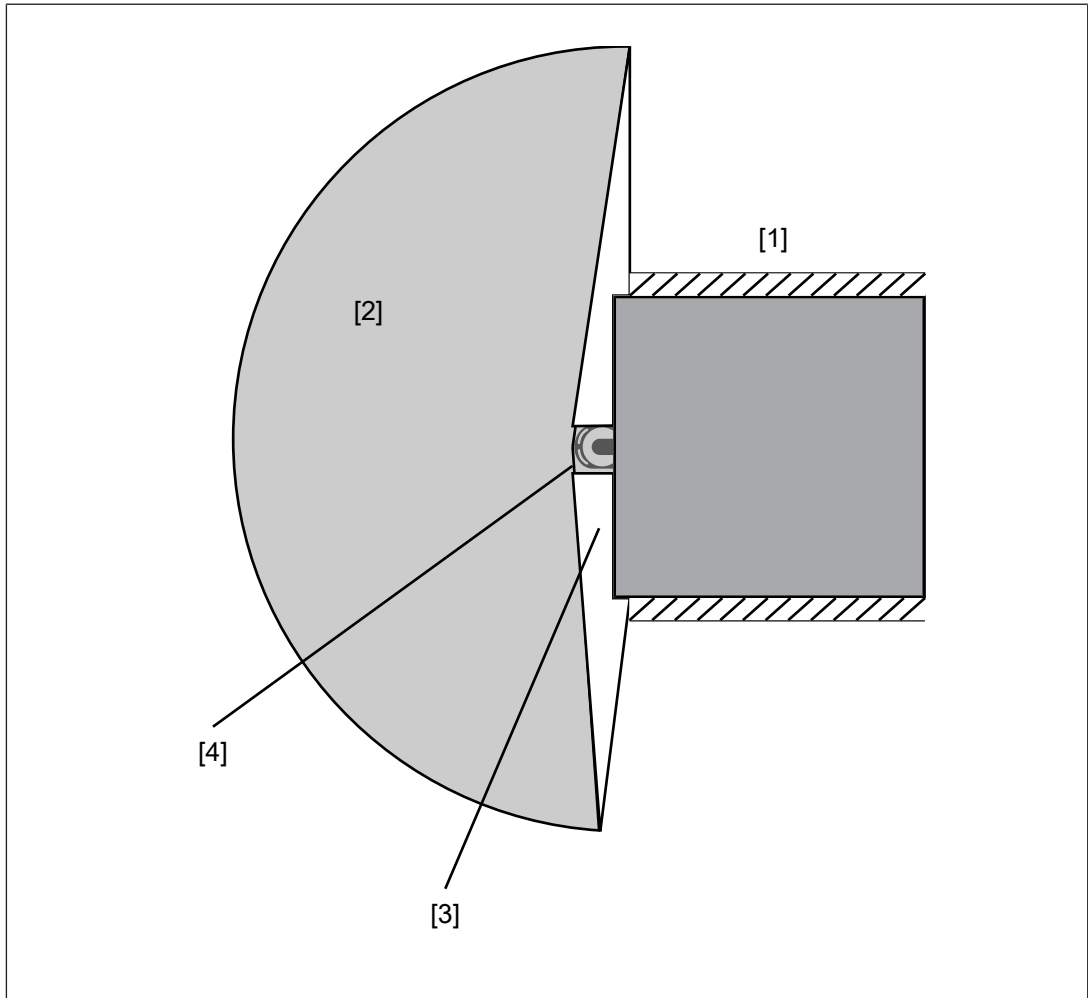

Legend

- [1] Danger zone with fence
- [2] Safeguarded area
- [3] Not safeguarded area - safeguard against stepping behind
- [4] Safety laser scanner

Prevent creeping underneath

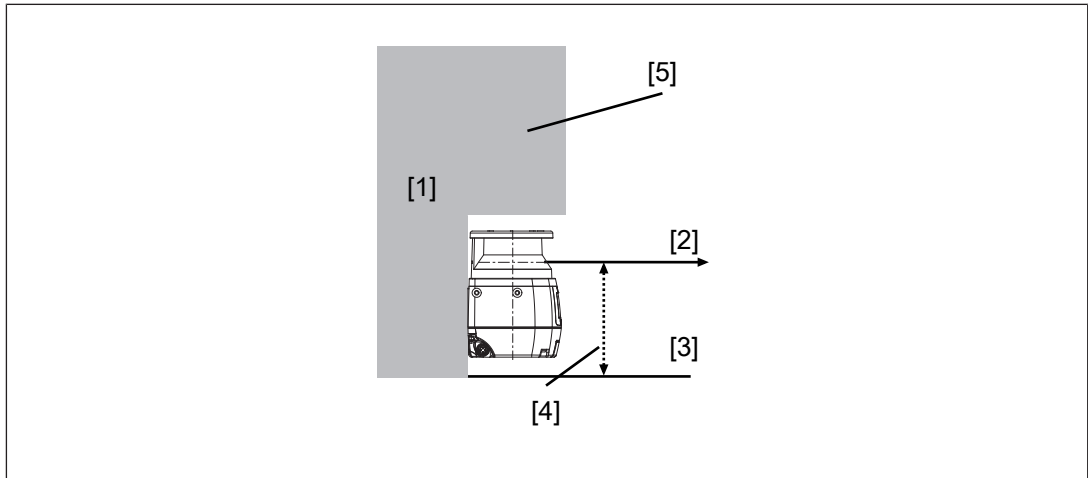

Legend

- [1] Mounting surface
- [2] Scanning plane
- [3] Base area
- [4] Safeguard area against creeping underneath
- [5] Edge at the mounting surface

8 PSEnscan Configurator

8.1 Basics

The PSEnscan Configurator is a graphic tool

- ▶ For configuration of the safety laser scanners of the PSEN sc L 3/5 series,
- ▶ For incorporation of the safety laser scanner into the network,
- ▶ For monitoring the safety laser scanners in the network,
- ▶ For creating reports,
- ▶ For password administration of the safety laser scanner of the PSEN sc L 3/5 series

8.2 Installation

8.2.1 System requirements

Operating system:	Windows 7, 10 or XP (32 Bit and 64 Bit)
Processor:	Pentium 4, min. 2 GHz 3 GHz recommended
RAM:	Min. 2 GB
Available hard drive space:	Approx. 70 MB
Graphics card:	Min. 1024 x 768 pixel resolution, 65536 colours For optimum performance of the system, a current graphics card with 3D acceleration should be used, and the 3D acceleration should be activated.
To view the documentation:	Adobe Acrobat Reader, from Version 7.1.0
Interfaces:	A free 100 Mbps Ethernet interface for data transfer to the safety laser scanner
Access rights:	Network access for PSEnscan Configurator, profile Private

8.2.2 Install PSEnscan Configurator

Procedure:

1. Switch on your computer and start up the operating system.
2. Download the software PSEnscan Configurator from the download area on the Pilz homepage under <http://www.pilz.com/support/downloads/>.
3. Double-click on the unpacked file.

The software PSEnscan Configurator is installed.

The installer will guide you through the installation.

**INFORMATION**

To ensure that PSENScan Configurator functions correctly, the files and directories in the installation directory of PSENScan Configurator must not be modified manually once installed (e.g. with the Windows Explorer or a text editor).

8.2.3 Ethernet Connections

8.2.3.1 Factory default settings for the IP addresses

The factory-set default of the IP address of the safety laser scanner: 192.168.0.10.

**INFORMATION****Use the correct IP address**

A second address has been set up for internal functions of the safety laser scanner. This address always follows directly after the IP address, specified in the network settings.

- Ensure that only one IP address is used when the following IP address is not assigned.

8.2.3.2 Create firewall rule

A firewall or any other security mechanisms on the PC and network may prevent the PSENScan Configurator from communicating correctly with the connected devices. In this case, it will be necessary to adjust the security settings and firewall settings.

Firewalls allow access to explicitly registered programs. The following program must have access to the profile **Private**:

- ▶ PSENScan Configurator

8.2.3.3 Connect automatically

The PSENScan Configurator offers the option of automatically finding a device available in the network.

1. Select **Device -> Search device**.

The network is searched for connected devices of the PSEN sc L 3/5 series.

Connected devices of the PSEN sc L 3/5 series are listed under **Network environment**.



To locate the PSEN sc L 3/5 series click the button . The wave symbol is shown on the display of the selected PSEN sc L 3/5 series.

2. Double-click the safety laser scanner from **Network environment**.
The safety laser scanner is displayed in the work window with IP address, firmware version and status information.
3. Select **Settings -> Change network settings**.
Enter the password for the safety laser scanner (the factory default setting for the password is **admin**).
4. Enter the network data for connecting to the network and click **OK**.
5. The safety laser scanner switches to the OFF state. Click **OK** to continue.
6. The safety laser scanner is displayed automatically with an updated IP address.
7. Double-click on the device to create a new configuration.

8.3 Download configuration to device

You can use the **Download configuration to device** function to download the configuration in the PSENScan Configurator to a connected device. Once the configuration test has been completed, the new configuration in the connected device can be accepted or rejected.

Load configuration

1. Make sure that the **Download configuration** work window shows a report, listing the differences between the existing configuration on the connected device and the configuration in the PSENScan Configurator.
The configuration on the connected device is labelled DEV.
The configuration in the PSENScan Configurator is labelled GUI.
2. Check the whole report to ensure it is correct.
3. Click on Load.
The configuration in the PSENScan Configurator is downloaded to the connected device. The connected device goes offline as the configuration is being downloaded. The configuration settings will not be available again until you **Accept** or **Reject** the configuration.
4. Select **Monitoring** and check the downloaded configuration.
5. Select **Download configuration** and **Accept** or **Reject** the downloaded configuration.

Check

- ▶ Click **Accept** to activate the downloaded configuration in the connected device and reject the existing configuration on the connected device.
- ▶ Click **Reject** to reject the downloaded configuration in the connected device and continue to use the existing configuration on the connected device. The downloaded configuration in the connected device will be deleted.

8.4 Create backup copy of a configuration

For restoring an existing configuration (see [Restore configuration](#) [ 80]) you need a backup copy of this configuration.

Procedure:

- ▶ Select Project -> Save.

The dialogue box for saving is opened. Please enter a name for the MIB file.

The MIB file includes all the data for configuration.

9 First commissioning

9.1 Requirements for commissioning

Please note:

- ▶ Ensure that the window of the safety laser scanner is clean, intact and without fingerprints.



CAUTION!

Detection of safety zones being violated deteriorates

If the safety laser scanner is commissioned in deviating conditions, the detection of the safety zones being violated may deteriorate.

- Ensure that the conditions for commissioning are met.

9.2 System connection

Make sure that the selected evaluation device has the following property:

- ▶ OSSD signals are evaluated through 2 channels with plausibility monitoring

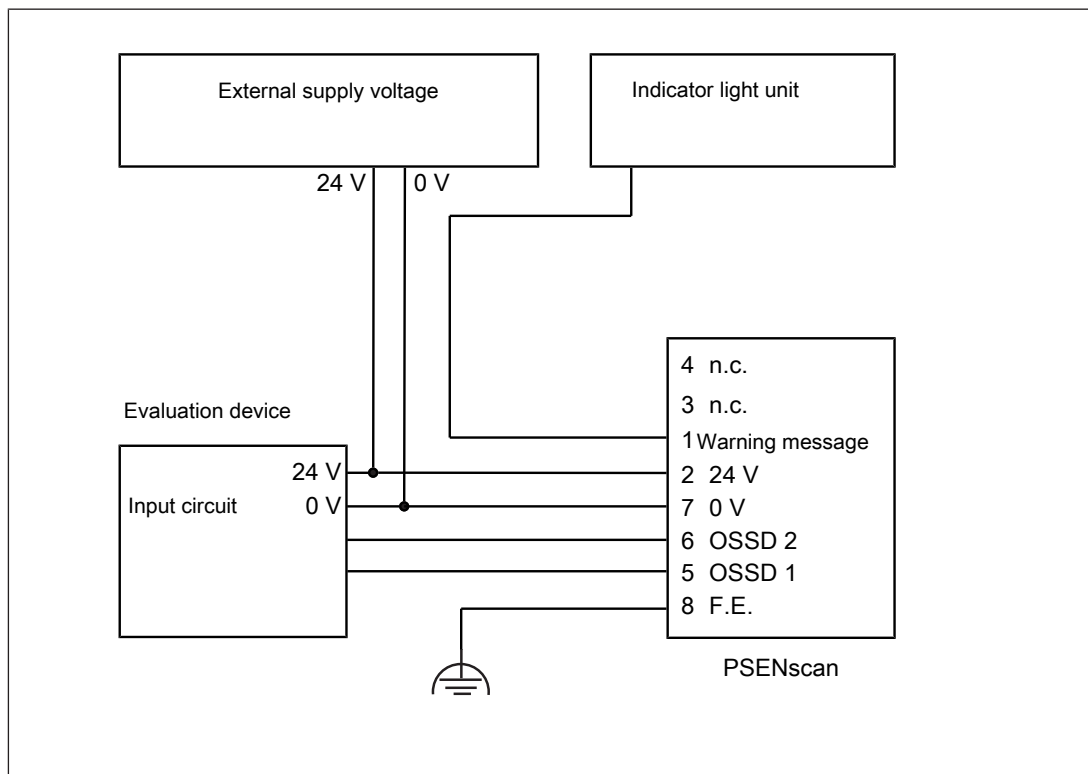

Fig.: Dual-channel connection of the safety laser scanner on the input circuit of an evaluation device (1 zone set, warning message, automatic restart)

Suitable Pilz evaluation devices are, for example:

- ▶ PNOZmulti for monitoring safety laser scanners
Configure the safety laser scanner in PNOZmulti Configurator as a function element "Light curtain" with switch type 3.
- ▶ Automation system PSS 4000

The correct connection to the respective evaluation device is described in the operating manual for the evaluation device. Connect the evaluation device according to the specifications in the selected evaluation device's operating manual.

9.3 Configuration of zones

For simultaneous monitoring of several zones and the switching of monitoring of zone sets, the configurable inputs of the safety laser scanner must be configured appropriately.

- ▶ Configuration of a static zone set
No configurable inputs are required.
- ▶ Configuration of two zone sets
Configure two configurable inputs.
- ▶ Configuration of three zone sets
Configure three configurable inputs.

9.3.1 Example for an 8-pin connection

Sample settings in PSEnscan Configurator for a safety laser scanner with 8-pin connection: Vertical application with reference outline monitoring, 1 zone set, no warning, automatic re-start, dynamic muting in one direction

Procedure:

1. From the start page, select **Create new configuration**.

The window **Device selection** is displayed with one tab each **Online** and **Overview of all types**.

2. Select a device from **Overview of all types**. Double-click the device.

The device is displayed in the work window and it can be configured.

3. Under **Application**, select VERTICAL and **8-pin connection**.

Configuration

You can enter a title for the configuration under **Name**.

You can enter the name of the person who created the configuration under **Author**.

You can describe the configuration in detail under **Description**.

The **Configurator Version** is entered by the system and cannot be changed.

The **Check sum** is entered by the system and cannot be changed.

The **Creation date** is entered by the system and cannot be changed.

Device

You can enter a title for the connected device under **Name**.

Click on the arrow  . The next window is opened: **Output configuration**. The number of OSSD pairs is already selected.

4. Select **Warning zone** = 0.

If **Warning zone** = 0, the warning zone is deselected. The output Pin 1 is automatically set to NOFUNCTION. The output cannot be used.

Select **Muting** = **Activated**

The outputs Pin 5 and 6 are reserved for OSSD 1 and OSSD 2 and cannot be changed.

Click on the arrow  . The next window **Configure zone sets** is opened.

5. Click on the arrow  . The next window **Configure zone sets** is opened.

Zone set = 1 is already selected. Further settings are not required.

Click on the arrow  . The next window **Input configuration** is opened

6. For **Restart** select the value **Automatic** and define the **Recovery time** (min. 200 ms, max. 60000 ms).

Select the **Muting type** and specify the value for **Muting activation delay [ms]**.

For **Muting type** = **L muting** a factor can be specified for an increase of the activation delay.

If necessary, specify a value for time monitoring of the muting function (**Time exceeded [min]** (0 = no time exceeded))

In **Input wiring** select the PINs to which the muting sensors are connected. For dynamic activation of the muting state, **Activate muting 1** must also be assigned to a PIN.



CAUTION!

Risk of injury due to loss of the safety function.

If time monitoring for the muting function is set to ∞ , the muting function is not cancelled until the muting sensors are no longer active.

This setting does not comply with the specifications of EN ISO 61496-1.

- Make sure that sustained muting is detected.

7. Click on the arrow  . The next window **Configure detection capability** is opened.

8. Under **Multiple evaluation**, define the number of consecutive scans needed for detection.

Increasing the number of consecutive scans will increase the response time of the safety laser scanner.

9. Select the **detection capability [mm]** for this safety laser scanner. Define the value for **Safety zone** or for **Warning zone**.

Please note:

With a resolution of 40 mm, the range of the safety zone expands to 3 m, and the range of the warning zone expands to 22 m.

10. Select **Dust filter level** (level 1 = low, level 3 = high).

A higher level of dust filtering requires a longer safety distance.



WARNING!

Loss of safety function due to a safety distance that is too low

Depending on the application, serious injury or death may result.

- ▶ Depending on the degree of dust filtering, it is necessary to consider an allowance for calculating the safety distance when installing the safety laser scanner near intense light sources or reflective surfaces into account (see [Distance to intense light sources and to reflective surfaces](#) [ 34]).
 - When calculating the safety distance, ensure that the allowance is considered depending on the dust filtering.
 - Ensure that the new safety distance fulfils the specifications of the safety assessment.

11. Click on the arrow  . The next window **Configure zones** is opened.

Create the zones using the symbols in the tool bar on the right-hand side.



12. Click on  .

Specify at least 3 (max. 15) reference points. Specify a max. permitted tolerance for each reference point. **Tol -** is the tolerance for the side that faces the safety laser scanner, **Tol +** is the tolerance for the side that is facing away from the safety laser scanner.

9.3.2 Example for an 12-pin connection

Settings in PSEnscan Configurator for a safety laser scanner with 12-pin connection: Vertical application with reference contour monitoring, 1 zone set, 1 warning, manual restart

Procedure:

1. From the start page, select **Create new configuration**.

The window **Device selection** is displayed with one tab each **Online** and **Overview of all types**.

2. Select a device from **Overview of all types**. Double-click the device.

The device is displayed in the work window and it can be configured.

3. Under **Application**, select VERTICAL and **12-pin connection**.

Configuration

You can enter a title for the configuration under **Name**.

You can enter the name of the person who created the configuration under **Author**.

You can describe the configuration in detail under **Description**.

The **Configurator Version** is entered by the system and cannot be changed.

The **Check sum** is entered by the system and cannot be changed.

The **Creation date** is entered by the system and cannot be changed.

Device

You can enter a title for the connected device under **Name**.

Click on the arrow **>**. The next window is opened: **Output configuration**. The number of OSSD pairs is already selected.

4. Select **Warning zone** = 0.

If **Warning zone** = 0, the warning zone is activated. The output Pin 1 is automatically set to NOFUNCTION. The output cannot be used.

Outputs Pin 5 and 6 are reserved for OSSD 1 and OSSD 2 and cannot be changed.

Click on the arrow **>**. The next window **Configure zone sets** is opened.

5. Select **Zone set** = 3 and enter for the PINs 1, 3 and 4 each the **Zone switching**. Enter the input delay.

For the configuration of switchable zones the PINs 1, 3 and 4 have to be assigned to the zone sets. You can make the assignment automatically using PSEnscan Configurator or perform it manually.

Automatic assignment using PSEnscan Configurator



Click  for automatic specification of the coding of zone sets

Manual assignment

For **Zone set 1** enter **AS3 = 1**.

For **Zone set 2** enter **AS2 = 1**.

For **Zone set 3** enter **AS1 = 1**.

Assignment of input signals

For PIN 1, enter AREA SWITCH 3.

For PIN 3, enter AREA SWITCH 1.

For PIN 4, enter AREA SWITCH 2.

Click on the arrow **>**. The next window **Input configuration** is opened.

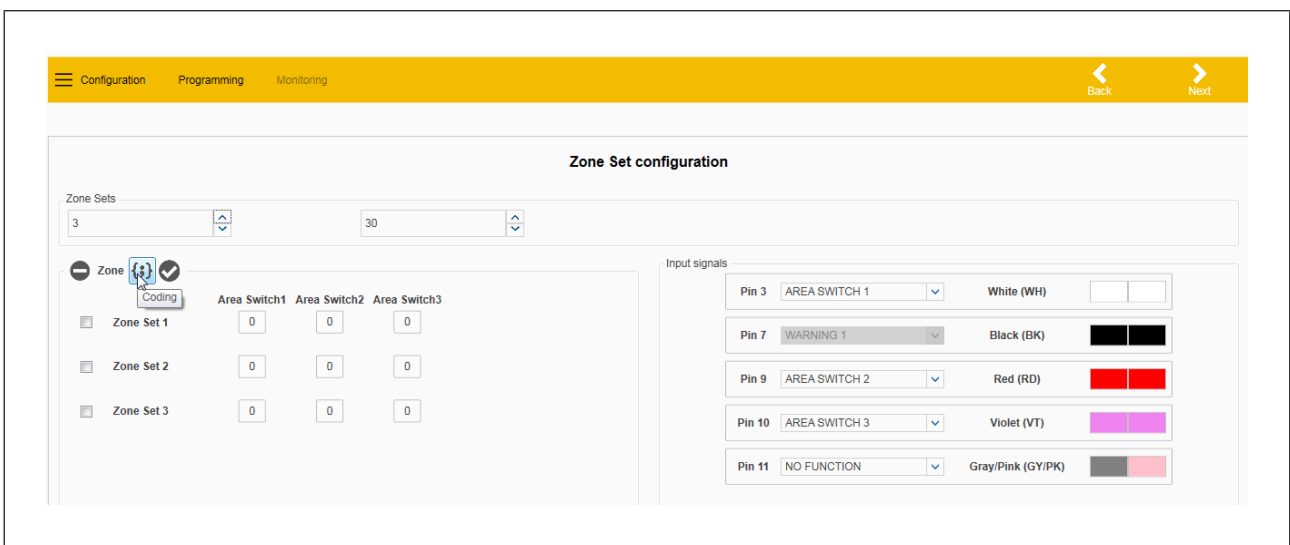

6. For **Restart** select the value **Automatic** and define the **Recovery time** (min. 200 ms, max. 60000 ms).
Select whether **EDM** is to be activated. When EDM is activated, a PIN must be assigned to the EDM input.
7. Click on the arrow . The next window **Configure detection capability** is opened.
8. Under **Multiple evaluation**, define the number of consecutive scans needed for detection.
Increasing the number of consecutive scans will increase the response time of the safety laser scanner.
9. Select the **detection capability [mm]** for this safety laser scanner. Define the value for **Safety zone** or for **Warning zone**.
10. Select **Dust filter level** (level 1 = low, level 3 = high).
A higher level of dust filtering requires a longer safety distance.



WARNING!

Loss of safety function due to a safety distance that is too low

Depending on the application, serious injury or death may result.

- ▶ Depending on the degree of dust filtering, it is necessary to consider an allowance for calculating the safety distance when installing the safety laser scanner near intense light sources or reflective surfaces into account (see [Distance to intense light sources and to reflective surfaces \[34\]](#)).
 - When calculating the safety distance, ensure that the allowance is considered depending on the dust filtering.
 - Ensure that the new safety distance fulfils the specifications of the safety assessment.

11. Click on the arrow . The next window **Configure zones** is opened.
Create the zones using the symbols in the tool bar on the right-hand side.



12. Click on .
Specify at least 3 (max. 15) reference points. Specify a max. permitted tolerance for each reference point. **Tol -** is the tolerance for the side that faces the safety laser scanner, **Tol +** is the tolerance for the side that is facing away from the safety laser scanner.

9.4 Testing

Before finally commissioning the safety laser scanner after the installation and alignment, final inspections must be carried out.



INFORMATION

This inspection may only be carried out by qualified personnel.

Check safety function of the safety laser scanner

Procedure:

As a test piece, use an opaque object with a height of at least 300 mm and a diameter that corresponds to the selected detection capability.

Move the test piece at various points along the safety zone into the safety zone:

The OSSDs must switch to the OFF state with each entry of the test piece.

Check ambient conditions and installation

- ▶ Correct alignment and fixing
Check that the fixing screws of the safety laser scanner are firmly seated.
- ▶ Safety distance
The safety distance must comply with the requirements in [Maintaining the safety distance](#) [27].
- ▶ Circumventing the safety zone
The danger zone must be safeguarded so that it is impossible to access by circumventing the safety zone.
- ▶ Safety zone perimeters
The safety zone perimeters (see [Project configuration](#) [26]) must completely safeguard the danger zone, making it inaccessible.
- ▶ Position of the pushbutton for manual restart
It must not be possible to operate the pushbutton for manual restart from inside the danger zone. The pushbutton must be located at a position from which there is a full, unobstructed view of the danger zone.
- ▶ Response time and stopping time must fulfil the requirements in [Maintaining the safety distance](#) [27].
Ensure that the safety laser scanner's response time and the machine's stopping time fulfil the requirements [Maintaining the safety distance](#).
- ▶ Intense or flashing light sources in the vicinity
The allowance Z_R for particularly intense or flashing light sources near the safety laser scanner (range of +/- 5° to the scan level or highly reflective background within a distance of 2.5 m to the safety zone perimeter) has been considered when calculating the safety distance (see [Distance to intense light sources](#) [34]).
- ▶ Ambient conditions
Please observe the [environmental conditions](#) [34].

- ▶ Check the safety laser scanner's front panel.
 - Scratched front panel: Change the safety laser scanner.
 - Dirty front panel: [Clean the front panel](#)  83].

Create backup copy of a configuration













- ▶ After successfully checking the installation and configuration of the safety laser scanner, create a backup copy of the configuration.



Procedure:

- ▶ Select Project -> Save.
The dialogue box for saving is opened. Please enter a name for the MIB file.
The MIB file includes all the data for configuration.









10 Operation

10.1 Display during normal operation

Message in the display		Status	Description/measure
Icon	Text		
	CLEANW2	The front panel must be cleaned	Decommission the safety laser scanner. Clean the safety laser scanner's front panel [ 82].
	DLDNC	Download of a configuration or a report	A configuration or a report is downloaded.
		The status of the network is checked	The status of the safety laser scanner in the network is checked.
	ITLOCK1	Safety laser scanner in interlock condition	The safety laser scanner is in interlock condition. Normal operation is possible only after a successful restart of the safety laser scanner.
	INPUTCF1	Faulty input	Faulty input, e.g. wrong number of inputs that are used for switching the zone sets.
	NOCONF	No configuration available	No configuration for the safety laser scanner could be found.
		The wave function is activated.	The symbol flashes. Select the safety laser scanner in PSENscan Configurator and configure it.
	MUT TIMEOUT	Muting has elapsed (timeout).	
	MUTING ERR	Could not activate muting because the specifications for activating the muting sensors were not met.	
	MUTING	Muting on OSSD1 is active. The OSSDs are in the ON state.	
	OVERRIDE ERR	Could not activate override because the specifications for activation were not met.	

Message in the display		Status	Description/measure
Icon	Text		
	OVERRIDE	Override is active.	
	OVR TIMEOUT	Override has elapsed.	

10.2 Display of the monitoring status





Icon		Status	Description/measure
Valid configuration	Configuration not yet accepted		
		Device is switched on and ready for operation	
		Warning zone has been violated	A violation of the warning zone has been detected. The configured action for a violation of the warning zone has been triggered.
		Safety zone has been violated	A violation of the safety zone has been detected. The OSSDs are in the OFF state.
		Change detected in the reference outline	A violation of the reference outline has been detected. The area of change is highlighted in blue. Check the cause for the change and eliminate the cause or adapt the reference outline.

10.3 Diagnostic information





10.3.1 Error

Message in the display		Error/cause	Description/measure
Icon	Text		
	CLEANW1	The front panel of the safety laser scanner must be cleaned.	Clean front panel
	INPUTCF1	Error in the configuration or the wiring.	Check whether the wiring [45] and the configuration [66] will match.
	INPUTCF2	Configuration error.	In the configuration, check the configured state transitions and switching operations.
	INTF1	An error occurred during the system test.	Perform a reset of the safety laser scanner [81] . If the error persists, please contact Pilz.
	INTF2	An error occurred during the system test.	Perform a reset of the safety laser scanner [81] . If the error persists, please contact Pilz.
	INTF3	An error occurred during the system test.	Perform a reset of the safety laser scanner [81] . If the error persists, please contact Pilz.
	INTF4	An error occurred during the system test.	Perform a reset of the safety laser scanner [81] . If the error persists, please contact Pilz.
	INTF5	An error occurred during the system test.	Perform a reset of the safety laser scanner [81] . If the error persists, please contact Pilz.
	INTF7	An error occurred during the system test.	Perform a reset of the safety laser scanner [81] . If the error persists, please contact Pilz.







Message in the display		Error/cause	Description/measure
Icon	Text		
	INTF8	An error occurred during the system test.	Perform a reset of the safety laser scanner [81]. If the error persists, please contact Pilz.
	INTF9	An error occurred during the system test.	Perform a reset of the safety laser scanner [81]. If the error persists, please contact Pilz.
	INTF10	An error occurred during the system test.	Perform a reset of the safety laser scanner [81]. If the error persists, please contact Pilz.
	INTF11	An error occurred during the system test.	Perform a reset of the safety laser scanner [81]. If the error persists, please contact Pilz.
	INTF12	An error occurred during the system test.	Perform a reset of the safety laser scanner [81]. If the error persists, please contact Pilz.
	INTF13	An error occurred during the system test.	Perform a reset of the safety laser scanner [81]. If the error persists, please contact Pilz.
	INTF14	An error occurred during the system test.	Perform a reset of the safety laser scanner [81]. If the error persists, please contact Pilz.
	INTF15	An error occurred during the system test.	Perform a reset of the safety laser scanner [81]. If the error persists, please contact Pilz.
	INTF16	An error occurred during the system test.	Perform a reset of the safety laser scanner [81]. If the error persists, please contact Pilz.
	INTF17	An error occurred during the system test.	Perform a reset of the safety laser scanner [81]. If the error persists, please contact Pilz.

Message in the display		Error/cause	Description/measure
Icon	Text		
	INTF18	An error occurred during the system test.	Perform a reset of the safety laser scanner [81]. If the error persists, please contact Pilz.
	INTF20	An error occurred during the system test.	Perform a reset of the safety laser scanner [81]. If the error persists, please contact Pilz.
	OSSD1F3	Earth fault has occurred on OSSD1.	Check the EDM state and the wiring of the OSSDs [45]. If the error persists, please contact Pilz.
	OSSDF1	An error has occurred when testing the OSSD1.	Check the EDM state and the wiring of the OSSDs [45]. If the error persists, please contact Pilz.

10.3.2 Warnings



Message in the display		Error/cause	Description/measure
Icon	Text		
	BOOTF	An error has occurred when starting the system.	Perform a reset of the safety laser scanner [81]. If the error persists, please contact Pilz.
	INTF6	An error occurred during the system test.	Perform a reset of the safety laser scanner [81]. If the error persists, please contact Pilz.
	EXTTEMP	The ambient temperature is outside the temperature range indicated in the Technical details.	Ensure that the ambient temperature is in the temperature range specified in the Technical details [86].
	OVERTEMP	The temperature of the safety laser scanner is outside the permitted temperature range.	
	HIGH REFL-BKG	The reflection of the background is too strong.	Reduce the background reflection or increase the safety distance (see Distance to intense light sources and to reflective surfaces [34]).

10.3.3 Information

Message in the display		Error/cause	Description/measure
Icon	Text		
	CLEANW2	The front panel of the safety laser scanner is contaminated and it must be cleaned to ensure normal operation.	Clean front panel
	DLDNC	A new configuration is downloaded.	
	DLDNF	A new firmware version is downloaded.	
	ITLOCK1	OSSD must be restarted	Perform a reset of the safety laser scanner [ 81].
	WAITING CONF	The safety laser scanner waits for a configuration (e.g. after restoring a configuration).	Configure the safety laser scanner (see Configuration of zones [ 66]).

10.4 Text messages in the display

With the buttons under the display of PSEN sc L 3/5 series you can navigate in the message in the display.

	Confirm message in the display and open the next menu level or exit the last menu level
	Scroll down
	Scroll up

The LC display shows information and navigates the menu with the sections Information, Setting and Exit.

Information

Menu item	Menu second level	Meaning
Hardware		Device-specific displays
	Device name	The name of PSEN sc L 3/5 series is displayed.
	Product name	The product type of PSEN sc L 3/5 series is displayed.
	Order number	The order number of PSEN sc L 3/5 series is displayed.

Menu item	Menu second level	Meaning
	Serial number	The serial number of PSEN sc L 3/5 series is displayed.
	Firmware version	The firmware version of PSEN sc L 3/5 series is displayed.
	Device Lifetime (h)	The current operating time of PSEN sc L 3/5 series in hours is displayed
Configuration		Configuration-specific displays
	Configuration name	The name is displayed under which the configuration was saved in PSENscan Configurator.
	Check sum	The check sum is displayed that was created when saving the configuration.
	Last saved date	Date of last modification of the project
	IP address	The first IP address of the PSEN sc L 3/5 series is displayed.
	MAC address	The MAC address of the PSEN sc L 3/5 series is displayed.

Setting

Menu item	Menu second level	Meaning
Display settings		
	Rotate	The display is rotated.
Reset PSENscan		Confirming starts a reset of the PSEN sc L 3/5 series.

Exit

Exit menu in the display.

10.5 Restore configuration

Prerequisites

- ▶ The memory module is installed correctly.
- ▶ The pin assignment must be compatible with the data in the memory module.

One of the following conditions must be met.

- ▶ The MIB files in PSEN sc L and in the memory module are different.
- ▶ The topologies in PSEN sc L and in the memory module are different.
- ▶ The serial numbers saved in PSEN sc L and in the memory module are different.

Procedure:

1. Switch the safety laser scanner on.

When the safety laser scanner is already switched on, switch it off and then on again.

The system checks whether the conditions are met. When the conditions are met, restoring of the configuration is started.

2. Depending on the type of difference between memory module and PSEN sc L the restoring of the configuration varies.

Serial numbers differ: CFG NO MATCHING is shown on the display. Continue by selecting the data for the restore.

Topology or MIB files vary: WAITING CONF is shown on the display. Continue the configuration in PSENscan Configurator.

3. Use the buttons on the display to select the data to be used for restore.

Display:

Restore cfg: The configuration in the memory module is used. Confirm the selection with **Confirm** and the configuration is copied from the memory module into PSEN sc L. Continue checking the configuration.

cfg from GUI: The configuration created newly in the PSENscan Configurator is used. Confirm your selection with **Confirm** and continue with Create new configuration in PSENscan Configurator.

4. Display: **Confirm / Cancel**

Confirm your entry with **Confirm**

5. Checking the configuration

Display:

RESTORE FAILED. Could not copy the configuration successfully. Continue by selecting the data for the restore.

RUN TEST MODE: Select **Enter Test** on the display. Test operation starts. Continue with accept or reject configuration.

6. Accept or reject configuration

Test operation is complete.

Select **Validate conf** to accept the configuration. The safety laser scanner is ready for operation again.

Select **Reject conf** to reject the configuration. Continue by selecting the data for the restore.

7. Create new configuration in PSEnscan Configurator

Display: WAITING CONF

Configure the safety laser scanner in PSEnscan Configurator.

10.6 **Reset**

The Reset function can be used to set the safety laser scanner back to normal operation, when the safety laser scanner has changed to an error state because of a non-critical error.

Procedure:

Hold the reset pushbutton down for at least 500 ms.

11 Safety checks, maintenance and repair

11.1 Cleaning

The front panel and the underside of the metal cover on the upper side of the safety laser scanner need to be cleaned regularly. The frequency depends on the environmental conditions.



WARNING!

Loss of the safety function due to the use of improper cleaning agents

Improper cleaning agents can damage the front screen and lead to malfunctions.

- Use only the cleaning agents specified.

A scratched front panel can lead to errors of the safety laser scanner.

Contact Pilz and exchange the PSEN sc head when the front panel is scratched.

Contamination	Cleaning
Finger marks	Dampen PSEN sc cloth with a mild cleaning agent or PSEN sc cleaner (see Order references [91]) and clean the front panel in one go without rubbing
Sticking particles	Dampen PSEN sc cloth with a mild cleaning agent or PSEN sc cleaner (see order reference [91]) and clean the front panel in one go without rubbing
Loose, non-chafing particles	<ul style="list-style-type: none"> ▶ Vacuum or gently blow away the particles without touching ▶ Remove particles using PSEN sc cloth in one go without rubbing
Loose, chafing particles	<ol style="list-style-type: none"> 1. Vacuum or gently blow away the particles without touching 2. Remove particles using PSEN sc cloth in one go without rubbing
Oil drops	Dampen PSEN sc cloth with a mild cleaning agent or PSEN sc cleaner (see order reference [91]) and clean the front panel in one go without rubbing
Statically charged particles	<ol style="list-style-type: none"> 1. Vacuum particles without touching 2. Dampen PSEN sc cloth with a mild cleaning agent or PSEN sc cleaner (see order reference [91]) and clean the front panel in one go without rubbing

11.2 Checks

11.2.1 Regular check

Regular checks can bring to light changes to the plant/machine, safeguards and ambient conditions.

Pilz recommends that the safety laser scanner be checked every six months.

▶ Check the safety laser scanner's front panel.

– Scratched front panel: Change the safety laser scanner.

– Dirty front panel: [Clean the front panel](#)  82].

In a particularly dirty environment, front panel cleanliness should be checked more frequently.

▶ Check the tightness of the safety laser scanner.

All screws must be tightened to the torque specified in the [Technical details](#)  86].

▶ Check the safety function of the safety laser scanner (see [Check the safety function of the safety laser scanner](#)  71]).

11.2.2 Check after plant/machine modification

Check the safety laser scanner each time the plant/machine is modified. Changing the safety laser scanner or swapping components of the safety laser scanner should also be regarded as a modification.

You **must** comply with the requirements of the applicable national regulations.



INFORMATION

This inspection may only be carried out by qualified personnel.

The Appendix contains a [Checklist](#)  93] which should help you perform the safety check.

11.3 Maintenance

Other than cleaning the front panel, the safety laser scanner requires no other form of maintenance.

12 Dimensions

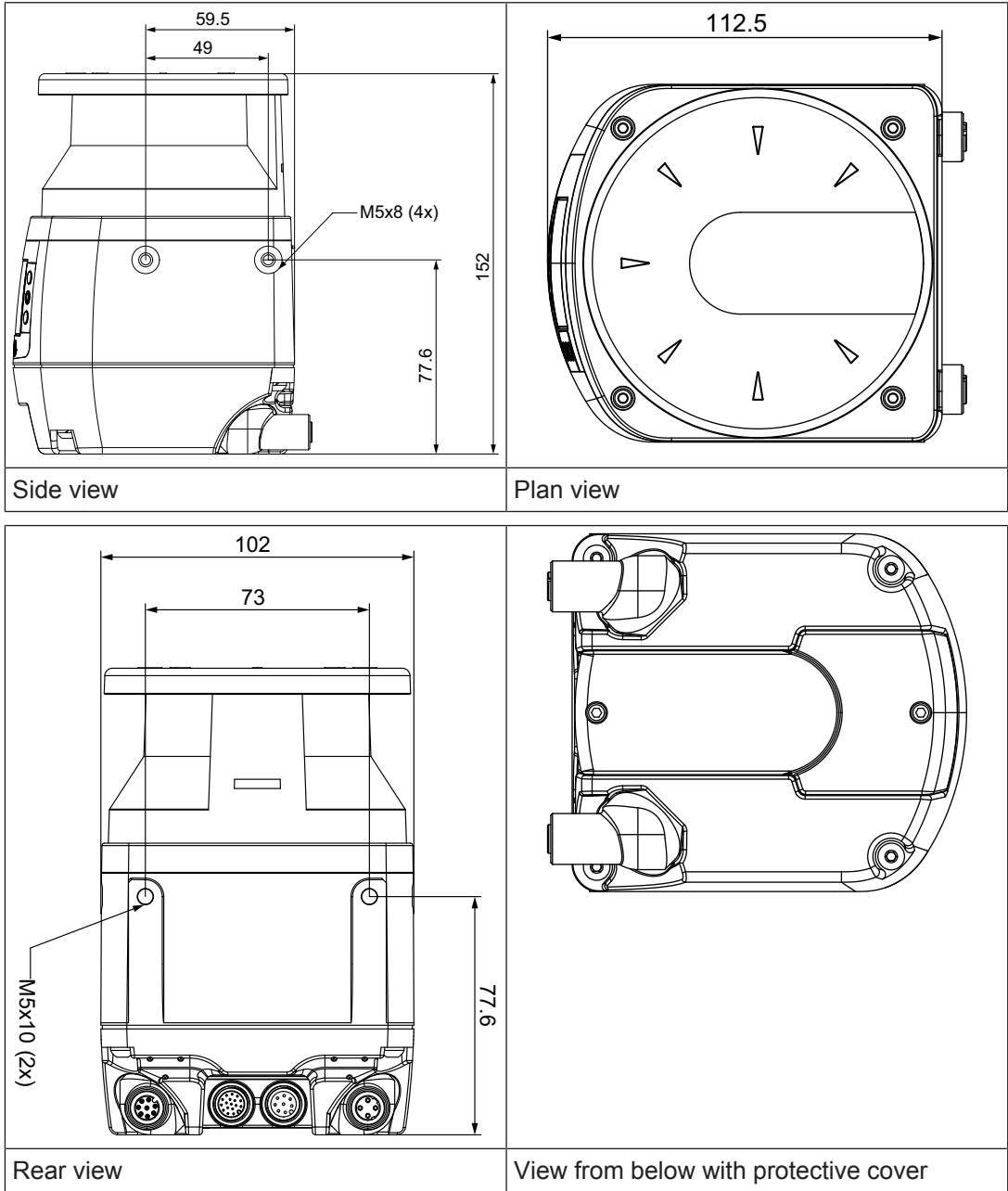

PSEN sc bracket PR

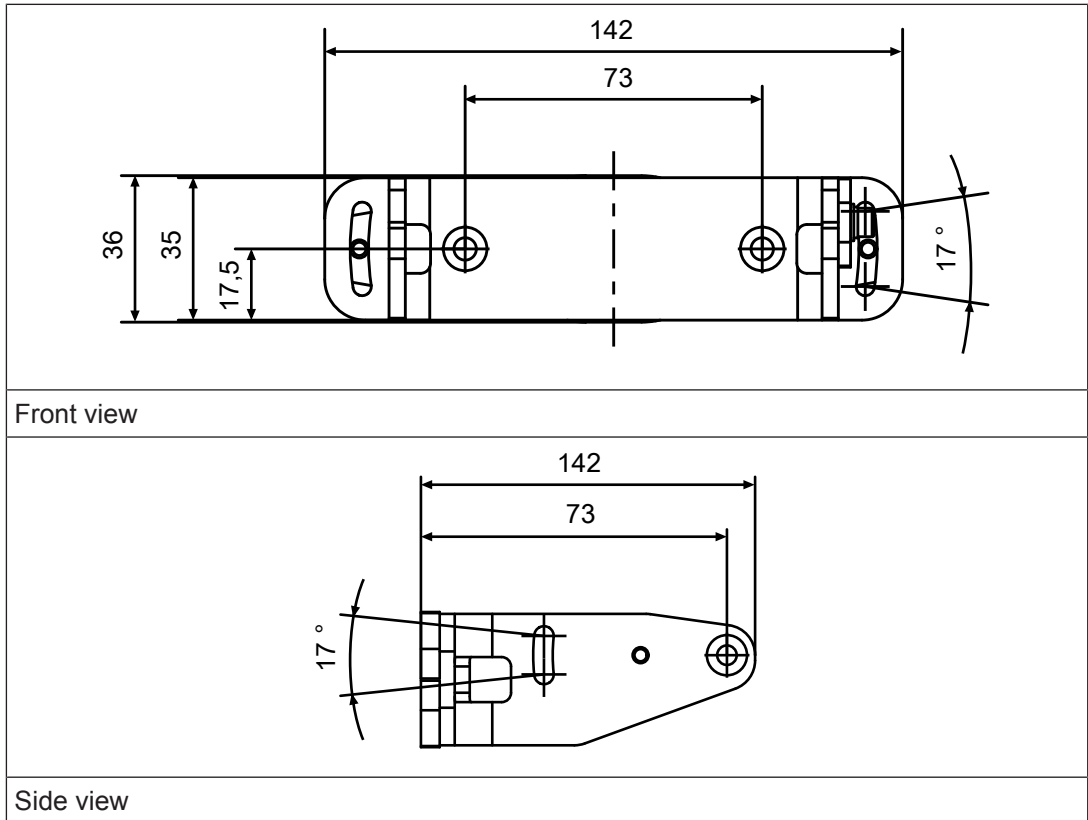

13 Technical details order no. 6D000012-6D000013

General	6D000012	6D000013
Certifications	CE, TÜV, cULus Listed	CE, TÜV, cULus Listed
ESPE type	3	3
Product type	Light	Light
Sensor's mode of operation	Optical	Optical
Resolutions	40 mm, 70 mm	40 mm, 70 mm
Number of zone sets that can be switched	10	10
Operating range		
Warning zone at 70 mm resolution	0,05 - 40 m	0,05 - 40 m
Warning zone at 40 mm resolution	0,05 - 22 m	0,05 - 22 m
Safety zone at 70 mm resolution	0,05 - 3 m	0,05 - 5,5 m
Safety zone at 40 mm resolution	0,05 - 3 m	0,05 - 3 m
Number of simultaneously monitored safety zones	1	1
Number of simultaneously monitored zones	2	2
Number of zone configurations	10	10
Electrical data	6D000012	6D000013
Supply voltage		
Voltage	24 V	24 V
Kind	DC	DC
Voltage tolerance	-20 %/+25 %	-20 %/+25 %
Output of external power supply (DC)	8 W	8 W
Max. output power	27 W	27 W
Residual ripple DC	5 %	5 %
Max. inductive load per output	2 H	2 H
Protection class	3	3
Optical data	6D000012	6D000013
Diameter light spot on front plate	8 mm	8 mm
Used wavelength range	905 nm	905 nm
Laser class (DIN EN 60825-1)	1	1
Scan area	275°	275°
Max. opening angle scanner	0,12°	0,12°
Angle resolution	0,1°	0,1°
Max. number multiple evaluation	16	16
Detectable remission area	1,8 - 1.000 %	1,8 - 1.000 %
Pulse duration	3 ns	3 ns
Typical output power laser	8 mW	8 mW
Measuring circuit	6D000012	6D000013
Input resistance	12 kOhm	12 kOhm

Configurable inputs/outputs (inputs or auxiliary outputs)		
	6D000012	6D000013
Number	1	1
Inputs		
Number	4	4
Signal level at "0"	< 5 V	< 5 V
Signal level at "1"	> 12 V	> 12 V
Voltage at inputs	24 V	24 V
Current per input	2 mA	2 mA
Semiconductor outputs		
OSSD safety outputs	2	2
Residual current at "0" signal	< 700 µA	< 700 µA
Output voltage at "1" signal	2 V	2 V
Output voltage at "0" signal	0 V	0 V
Max. output current at rated voltage	250 mA	250 mA
Max. capacitive load	2,2 µF	2,2 µF
Ethernet interface		
Number	1	1
Connection type	M12x1, 4-pin, D-code	M12x1, 4-pin, D-code
Transmission rate	100 MBit/s	100 MBit/s
Times		
Test pulse duration, safety outputs	300 µs	300 µs
Switch-on delay		
Typ. switch-on delay	40 s	40 s
Increased response time per measurement cycle	30 ms	30 ms
Response time t1	62 ms	62 ms
Rotation time	30 ms	30 ms
Environmental data		
Ambient temperature		
Temperature range	0 - 50 °C	0 - 50 °C
Storage temperature		
Temperature range	-20 - 70 °C	-20 - 70 °C
Climatic suitability		
Humidity	max. 95 %	max. 95 %
Condensation during operation	Not permitted	Not permitted
Vibration		
In accordance with the standard	EN 60068-2-6	EN 60068-2-6
Frequency	10 - 55 Hz	10 - 55 Hz
Amplitude	0,35 mm	0,35 mm

Environmental data	6D000012	6D000013
Shock stress		
In accordance with the standard	EN 60068-2-27	EN 60068-2-27
Number of shocks	1000	1000
Acceleration	10g	10g
Duration	16 ms	16 ms
Protection type		
Housing	IP65	IP65
Deviation from ideal flatness of the scan field at max. operating range	50 mm	50 mm
Mechanical data	6D000012	6D000013
Distance scanning plane to top edge	37,7 mm	37,7 mm
Distance mirror rotational axis to the rear	52,5 mm	52,5 mm
Connection type	M12, 12-pin male connector, M12, 8-pin male connector	M12, 12-pin male connector, M12, 8-pin male connector
Material		
Housing	Aluminium	Aluminium
Top	PC	PC
Front screen	PMMA	PMMA
Max. torque setting		
Fixing screw	3 Nm	3 Nm
Adjusting screw for angle of inclination	2,5 Nm	2,5 Nm
PSEN sc Memory	1 Nm	1 Nm
Dimensions		
Height	152 mm	152 mm
Width	102 mm	102 mm
Depth	112,5 mm	112,5 mm
Weight	1.530 g	1.530 g

Where standards are undated, the 2018-01 latest editions shall apply.

14 Safety characteristic data



NOTICE

You must comply with the safety characteristic data in order to achieve the required safety level for your plant/machine.

Operating mode	EN ISO 13849-1: 2015	EN ISO 13849-1: 2015	EN 62061 SIL CL	EN 62061 PFH _D [1/h]	IEC 61511 SIL	IEC 61511 PFD	EN ISO 13849-1: 2015
	PL	Category					T _M [year]
2-ch. OSSD	PL d	Cat. 3	SIL CL 2	6,38E-08	SIL 2	–	20

Explanatory notes for the safety-related characteristic data:

- ▶ The SIL CL value in accordance with EN 62061 corresponds to the SIL value in accordance with EN 61508.
- ▶ T_M is the maximum mission time in accordance with EN ISO 13849-1. The value also applies as the retest interval in accordance with EN 61508-6 and IEC 61511 and as the proof test interval and mission time in accordance with EN 62061.

All the units used within a safety function must be considered when calculating the safety characteristic data.



INFORMATION

A safety function's SIL/PL values are **not** identical to the SIL/PL values of the units that are used and may be different. We recommend that you use the PAScal software tool to calculate the safety function's SIL/PL values.

15 Network data

Interface	Protocol	Direction	Transport log	Port No.	Can be de-activated	Description
User interface	proprietary	out	UDP	2000	No	Monitoring
User interface	proprietary	in/out	UDP	3000	No	Receive command
User interface	proprietary	in/out	UDP	4088	No	Find device in network
User interface	proprietary	in/out	UDP	12000	No	Poll configuration data

16 Order reference

16.1 System

Product type	Features	Order no.
PSEN sc L 3.0 08-12	Safety laser scanner, range 3 m, light model, M12, 8/12-pin	6D000012
PSEN sc L 5.5 08-12	Safety laser scanner, range 5.5 m, light model, M12, 8/12-pin	6D000013

16.2 Accessories

Installation materials

Product type	Features	Order no.
PSEN sc bracket P R	Mounting bracket for setting the tilt of the angle of inclination and the roll angle	6D 000 002
PSEN sc bracket P	Mounting bracket for setting the tilt of the angle of inclination	6D 000 003
PSEN sc bracket C	Mounting bracket for corner mounting	6D 000 011
PSEN sc bracket F	Mounting bracket for floor mounting	6D 000 010
PSEN sc bracket H	Accessory for protection of the head part	6D 000 004
PSEN sc memory M12 08-12	Memory module 8- and 12-pin, M12	6D 000 006
PSEN sc cleaner	Antistatic cleaning agent	6D 000 008
PSEN sc cloth	Cleaning cloth	6D 000 009

Cable

Product type	Features	Connector X1	Connector X2	Connector X3	Order no.
PSEN cable axial M12 8-pole 3m	3 m	M12, 8-pin fe- male con- nector, straight			540 319
PSEN cable axial M12 8-pole 5m	5 m	M12, 8-pin fe- male con- nector, straight			540 320
PSEN cable axial M12 8-pole 10m	10 m	M12, 8-pin fe- male con- nector, straight			540 321
PSEN cable axial M12 8-pole 30m	30 m	M12, 8-pin fe- male con- nector, straight			540 326
PSEN cable M12-12sf 2m	2 m	M12, 12-pin fe- male con- nector, straight			570 350

Product type	Features	Connector X1	Connector X2	Connector X3	Order no.
PSEN cable M12-12sf 3m	3 m	M12, 12-pin female connector, straight			570 351
PSEN cable M12-12sf 5m	5 m	M12, 12-pin female connector, straight			570 352
PSEN cable M12-12sf 10m	10 m	M12, 12-pin female connector, straight			570 353
PSEN cable M12-12sf 20m	20 m	M12, 12-pin female connector, straight			570 354
PSEN cable M12-12sf 30m	30 m	M12, 12-pin female connector, straight			570 355
PSEN cable M12-12sf 50m	50 m	M12, 12-pin female connector, straight			570 356
PSEN op Ethernet cable 3m	3 m	M12, 4-pin male connector, straight	4-pin RJ45 male connector, straight		631 072
PSEN op Ethernet cable 10m	10 m	M12, 4-pin male connector, straight	4-pin RJ45 male connector, straight		631 073

17 Appendix

17.1 Check list

The check list below is intended as an aid in for the following work on a safety laser scanner of the PSEN sc L 3/5 series:

- ▶ During commissioning,
- ▶ recommissioning, and
- ▶ running the specified regular check.

Note that the check list is not intended to replace the plant-specific safety analysis required for commissioning/recommissioning, nor the resulting inspections and actions.



INFORMATION

Commissioning, recommissioning and regular inspection may only be carried out by qualified personnel.

We recommend that you keep the completed check list and store it with the machine documentation for reference.

Action	OK	Not OK	Notes
<p>Check the safety category/standards</p> <p>Does the safety category of the safety laser scanner match the safety category required for the plant/machine?</p> <p>Have the standards applicable for the plant/machine been considered?</p>			
<p>Check ambient conditions for safety laser scanner</p> <p>Have the environmental conditions been met (see Ambient conditions [📖 34])?</p> <p>Have the technical details been met for all the safety laser scanner components?</p>			
<p>Check access points to the danger zone</p> <p>Are all access points to the danger zone safeguarded either by safety laser scanners or by other safeguards?</p>			

Action	OK	Not OK	Notes
<p>Check minimum distance to danger zone</p> <p>Has the minimum distance been calculated in accordance with the applicable standards?</p> <p>Has the calculated minimum distance been maintained at all points?</p>			
<p>Check safety zone</p> <p>Has the ability to creep underneath the safety zone undetected been excluded?</p>			
<p>Check safety laser scanner</p> <p>Make sure that there are no objects in front of the safety laser scanner (e.g. trailing cables, crossbeams, struts, covers, etc.).</p> <p>Make sure that there are no transparent materials between the monitored safety zone and the safety laser scanner (such as the glass panel).</p> <p>Are all the mechanical connections on the safety laser scanner attached correctly?</p> <p>Are all the electrical connections to the safety laser scanner wired correctly?</p>			
<p>Check the effectiveness of the safety laser scanner during the hazardous movement</p> <p>Is the safety laser scanner effective throughout the whole of the hazardous movement of the plant/machine?</p>			
<p>Check the output circuitry of the programmable safety and control system</p> <p>Have OSSDs been incorporated as required for the desired safety category?</p> <p>Are the switching elements that are connected to the OSSDs (valves, contactors, etc.) monitored with feedback loops?</p> <p>Does the wiring of the OSSDs match the circuit diagram?</p>			

Action	OK	Not OK	Notes
Check the protective function of the safety laser scanner Violate the safety zone at various points: The hazardous movement must be shut down.			
Switch off the safety laser scanner Is the hazardous movement stopped immediately when you switch off?			

18 Identification

The safety laser scanner's year and month of manufacture is encoded within its serial number.

The serial number is a 9-digit code.

X YY M #####

Legend

X Internal designation (any letter)

YY Year of manufacture

16 = 2016

17 = 2017

18 = 2018

19 = 2019

...

30 = 2030

M Month of manufacture

A = January

G = July

B = February

H = August

C = March

I = September

D = April

L = October

E = May

M = November

F = June

N = December

Consecutive number within the month

19 EC declaration of conformity

This product/these products meet the requirements of the directive 2006/42/EC for machinery of the European Parliament and of the Council. The complete EC Declaration of Conformity is available on the Internet at www.pilz.com/downloads.

Authorised representative: Norbert Fröhlich, Pilz GmbH & Co. KG, Felix-Wankel-Str. 2, 73760 Ostfildern, Germany